

User Manual

Astraada HMI Panel PC
AS47I5B



Warning!

This equipment generates, uses and can radiate radio frequency energy and if not installed and used in accordance with the instructions manual, it may cause interference to radio communications. It has been tested and found to comply with the limits for a Class A computing device pursuant to FCC Rules, which are designed to provide reasonable protection against such interference when operated in a commercial environment. Operation of this equipment in a residential area is likely to cause interference in which case the user at his own expense will be required to take whatever measures may be required to correct the interference.

Electric Shock Hazard – Do not operate the machine with its back cover removed. There are dangerous high voltages inside.

Disclaimer

This information in this document is subject to change without notice. In no event shall Technology Inc. be liable for damages of any kind, whether incidental or consequential, arising from either the use or misuse of information in this document or in any related materials.

Packing List

Accessories (as ticked) included in this package are:
<input type="checkbox"/> Adaptor
<input type="checkbox"/> Driver & manual CD disc
<input type="checkbox"/> Other. _____ (please specify)

Safety Precautions

Follow the messages below to avoid your systems from damage:

- ◆ Avoid your system from static electricity on all occasions.
- ◆ Prevent electric shock. Don't touch any components of this card when the card is power-on. Always disconnect power when the system is not in use.
- ◆ Disconnect power when you change any hardware devices. For instance, when you connect a jumper or install any cards, a surge of power may damage the electronic components or the whole system.

Table of Contents

Warning!.....	2
Disclaimer.....	2
Packing List.....	3
Safety Precautions.....	3

Chapter 1 **Getting Started**

1.1 Specifications.....	6
1.2 Dimensions.....	7
1.3 Brief Description of AS47I5B.....	8
1.4 Installation of HDD.....	9
1.5 Installation of PCI Add-on.....	10

Chapter 2 **Hardware Installation**

2.1 Mainboard Specifications.....	11
2.2 Jumpers Setting and Connectors.....	16

Chapter 3 **BIOS Setup**

3.1 Operations after POST Screen.....	30
3.2 BIOS SETUP UTILITY.....	30
3.3 Main Settings.....	31
3.4 Advanced Settings.....	32
3.5 Chipset Settings.....	38
3.6 Boot Settings.....	43
3.7 Security Settings.....	45
3.8 Save & Exit Settings.....	46

Chapter 4 **Installation of Drivers**

4.1 Intel Chipset Driver.....	47
4.2 Intel VGA Chipset Driver.....	53
4.3 Intel Network Adapter Driver.....	57
4.4 Realtek Audio Driver Installation.....	60
4.5 Intel(R) USB 3.0 Driver Installation.....	62
4.6 Intel(R) AMT Installation.....	65

Figures

Figure 1.1: Dimensions of the AS47I5B.....	7
Figure 1.2: Left-front View of AS47I5B.....	8
Figure 1.3: Right-front View of AS47I5B.....	8
Figure 2.1: Mainboard Dimensions.....	11
Figure 2.2: Jumpers and Connectors Location-TOP.....	12
Figure 2.4: Jumpers and Connectors Location- Bottom.....	13

1.1 Specifications

Specs	AS47I5B
System	
CPU	Support Socket G2, 3rd Generation Intel Core i7/i5/i3
System Chipset	Intel HM77 PCH
System Memory	2 x 204 Pin DDR3 SO-DIMM, default 4GB (one slot), up to 16GB 1066/1333MHz
External I/O Port	2 x DB9 RS-232 (COM1.2) 1 x DVI-I 1 x HDMI 2 x RJ45 GbE LAN 4 x USB 2.0 1 x Mic-in, Line-Out 1 x DC Power 3 Pin terminal block connector 1 x 2 pin power switch connector 2X LED indication
OS Support	Windows XP embedded, Windows embedded standard 7, Windows 7 Pro for embedded
Expansion I/O By a new daughter board	By TB-523 1X Power button switch 1X CF Slot by USB 1X COM RS-422/485 (COM3, default:RS-485) 1X COM RS-232 (COM4) 1X10 pins terminal block for 1 Ground/VCC/ 4 in & out DIDO
Wi-Fi	2 optional Antenna holes at front side (conserved)
CD/DVD-R Device	Optional
Optional Fan	Two 40X40mm System Fan space, rear and front (080401030540)
Expansion Slots	1 x PCIe x16 and 1 x PCI slot By TB-526P1E161
Storage	2x 2.5" SATA HDD
Power	
Power Input	DC 9~32V
Power Consumption	Max:29.75W
Mechanical Specifications	
Construction / Color	Steel and Aluminum Heatsink
Dimensions(WxHxD)	211.2(W)x203.5(H)x177(D) mm
Net Weight	5.5KG
Environmental	
Operating Temperature	0~50 °C
Storage Temperature	-20~60 °C
Storage Humidity	10%~90% @ 40°C, non-condensing
Vibration	5G, 5-500MHz, 3 Axes(with CF or SSD) 0.5G 5-500MHz, 3 Axes(with HDD)
Shock	50G Half sine (11 msec. duration)/operation with SSD
Drop	92cm (1 Corner, 3 Edge, 6 Surface)
Certificate	CE / FCC Class A

1.2 Dimensions

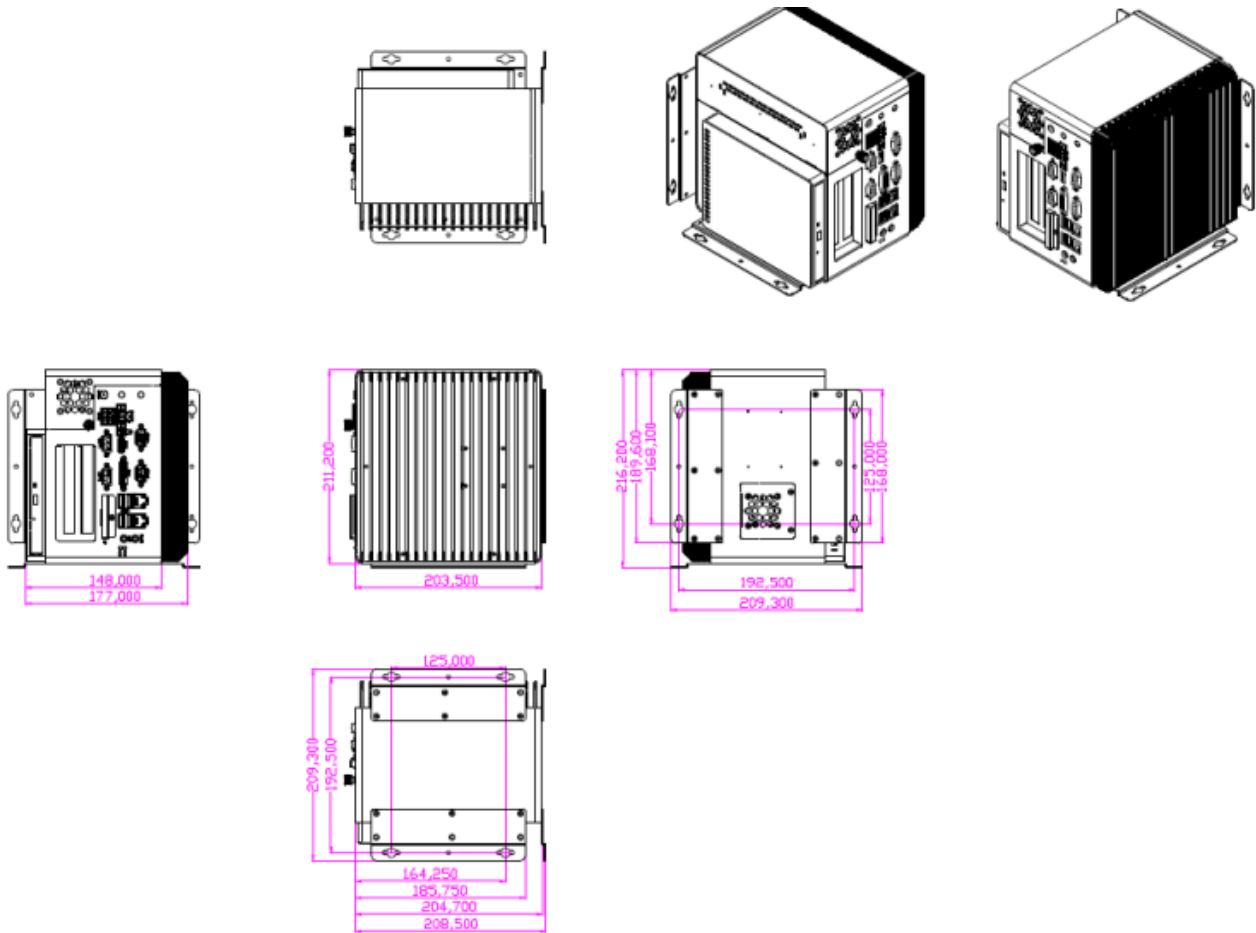

Figure 1.1: Dimensions of the AS47I5B

1.3 Brief Description of the AS47I5B

The AS47I5B is a fan-less high-efficiency thermal solution Box PC, powered by Socket G2, 3rd Generation Intel Core i7/i5/i3 processor and supporting 4 x USB 2.0 ports, 2 x COM Ports, 1 x DVI-I, support 2 x SATA HDD space, 1 x external CF slot, 9~32V wide-ranging power input etc. It is ideal for Industrial Automation, Factory Automation, Machine Vision, Process Control, Data Terminal, TI, Surveillance, etc. and running factory operations from small visual interface and maintenance applications to large control process applications. The AS47I5B works very well along with any of our Display series and it absolutely can provide an easy way to perform control and field maintenance.

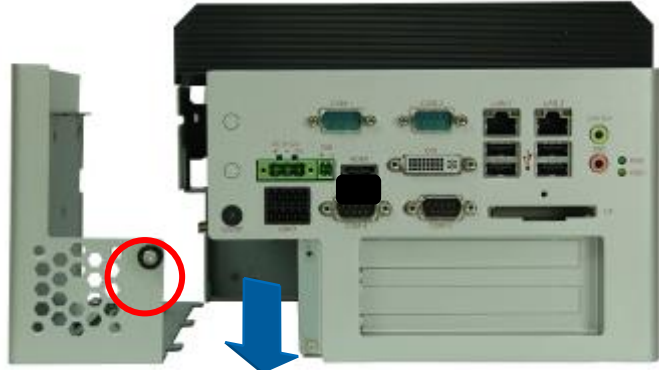
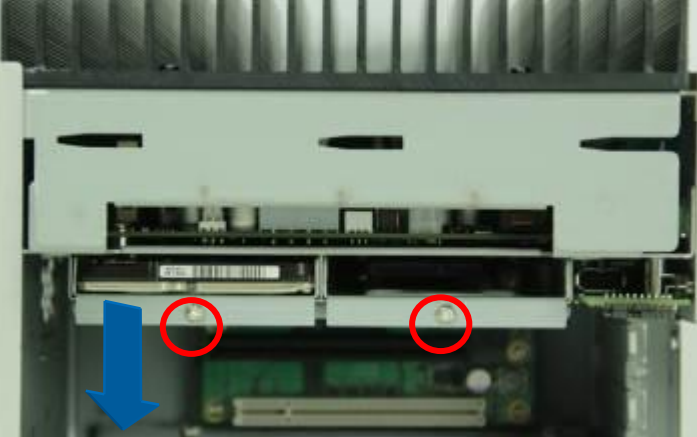
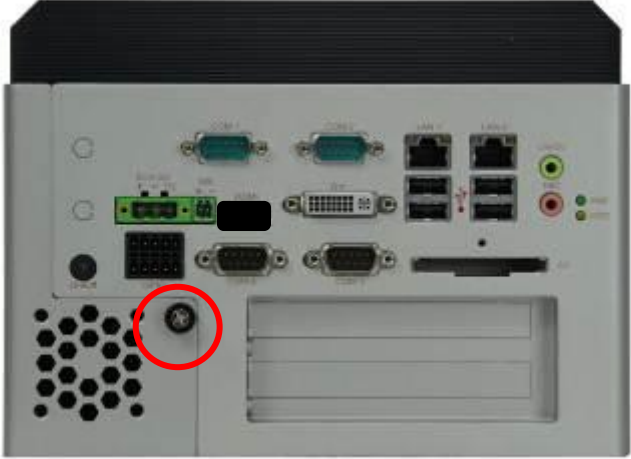

Figure 1.2: Left-front View of AS47I5B



Figure 1.3: Right-front View of AS47I5B

1.4 Installation of HDD

<p>Step 1 There is one screw which connects to the chassis. Pull out the chassis towards the I/O side after unscrewing as shown in the picture AS47I5B</p>	 A photograph of the rear panel of the AS47I5B chassis. A single screw on the left side is circled in red. A blue arrow points downwards from the circled screw, indicating the direction to pull the chassis out.
<p>Step 2 There are 2 screws to deal with when enclosing or removing the HDD bracket as shown in the picture AS47I5B</p> <p>Loosen screw and draw the HDD bracket out as shown in the picture AS47I5B</p>	 A photograph showing the internal components of the chassis. The HDD bracket is visible, and two screws on its front edge are circled in red. A blue arrow points downwards from the left side of the bracket, indicating the direction to pull it out.
<p>Step 3 Tighten the 1 screw as shown in the picture. That's how it should look after it has been installed.</p>	 A photograph of the rear panel of the AS47I5B chassis, showing the final state after installation. The screw on the left side is circled in red.

1.5 Installation of PCI Add-on

Step 1

There is one screw which connects to the chassis. Pull out the chassis towards the I/O side after unscrewing as shown in the picture AS47I5B

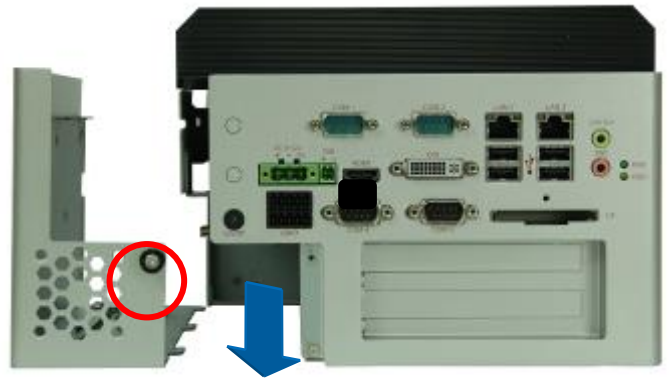

Step 2

Now slide the add on into the PCI slot, making sure the golden part faces the slot. When the part that is interfaced together come into the right contact, slightly push the add on into the rail of the slot.

After sliding the add on into the PCI expansion slot, get the one screw as circled tightened to finish the connection.

**** Half Expansion-card limit to be not more than 175mm length**

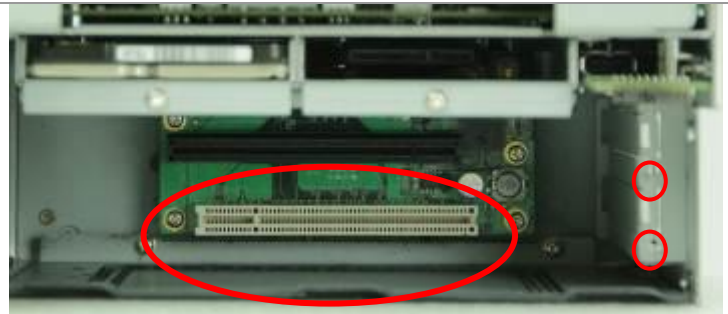

Step 3

Tighten the 1 screw as shown in the picture. That's how it should look after it has been installed.

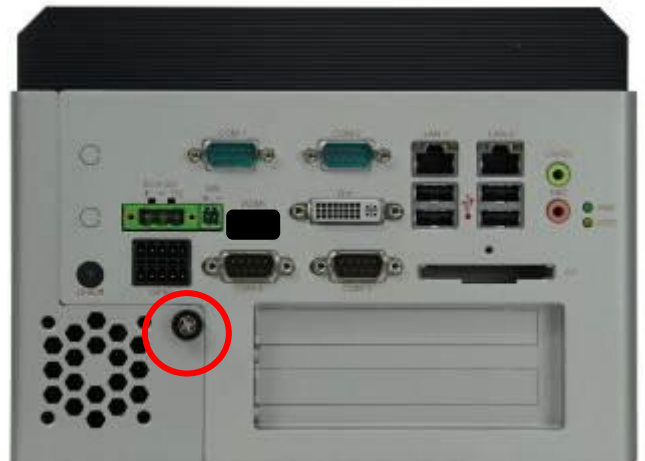

Chapter 2 Hardware Installation

2.1 Mainboard Specifications

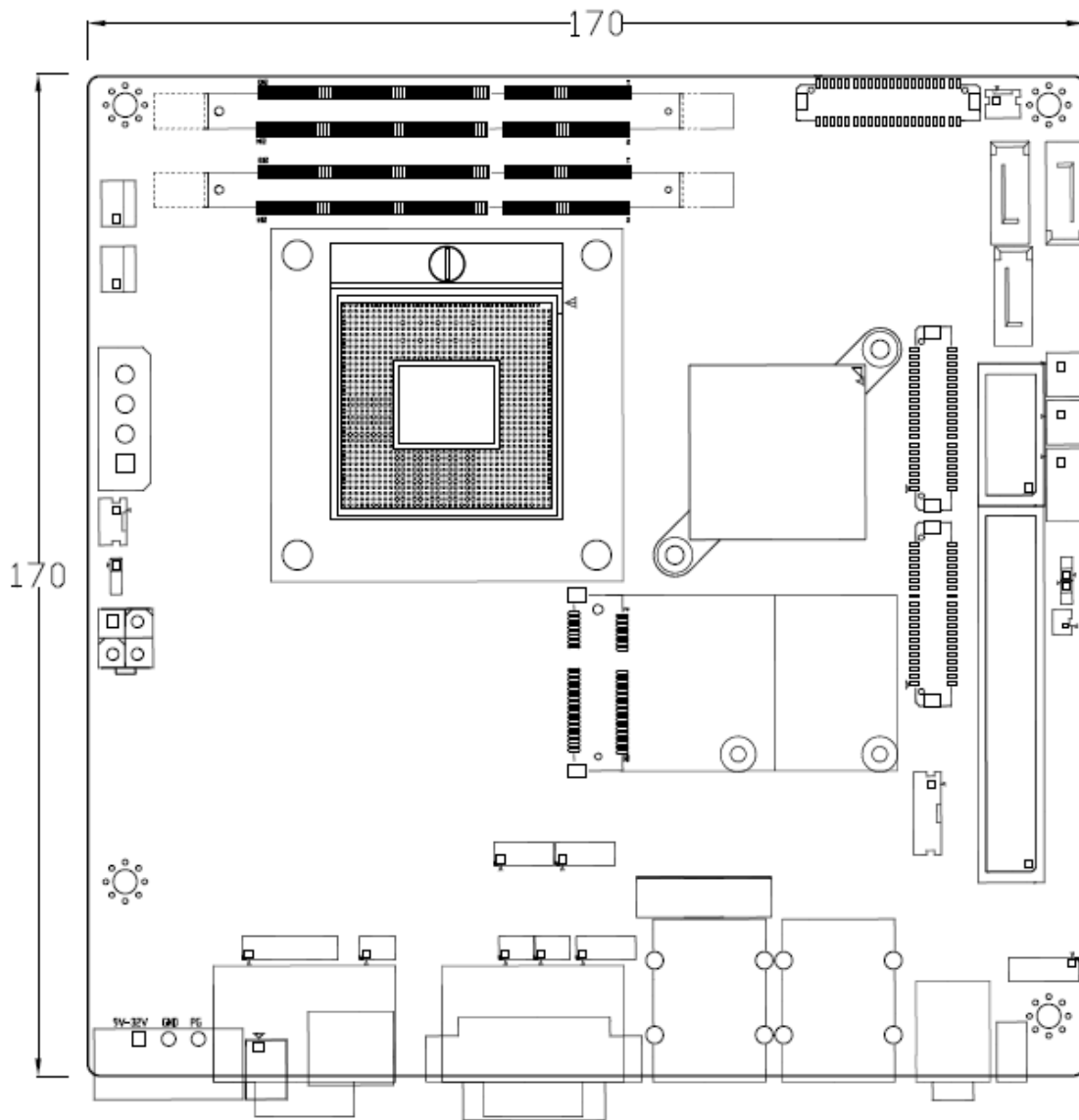

Figure 2.1: Mainboard Dimensions

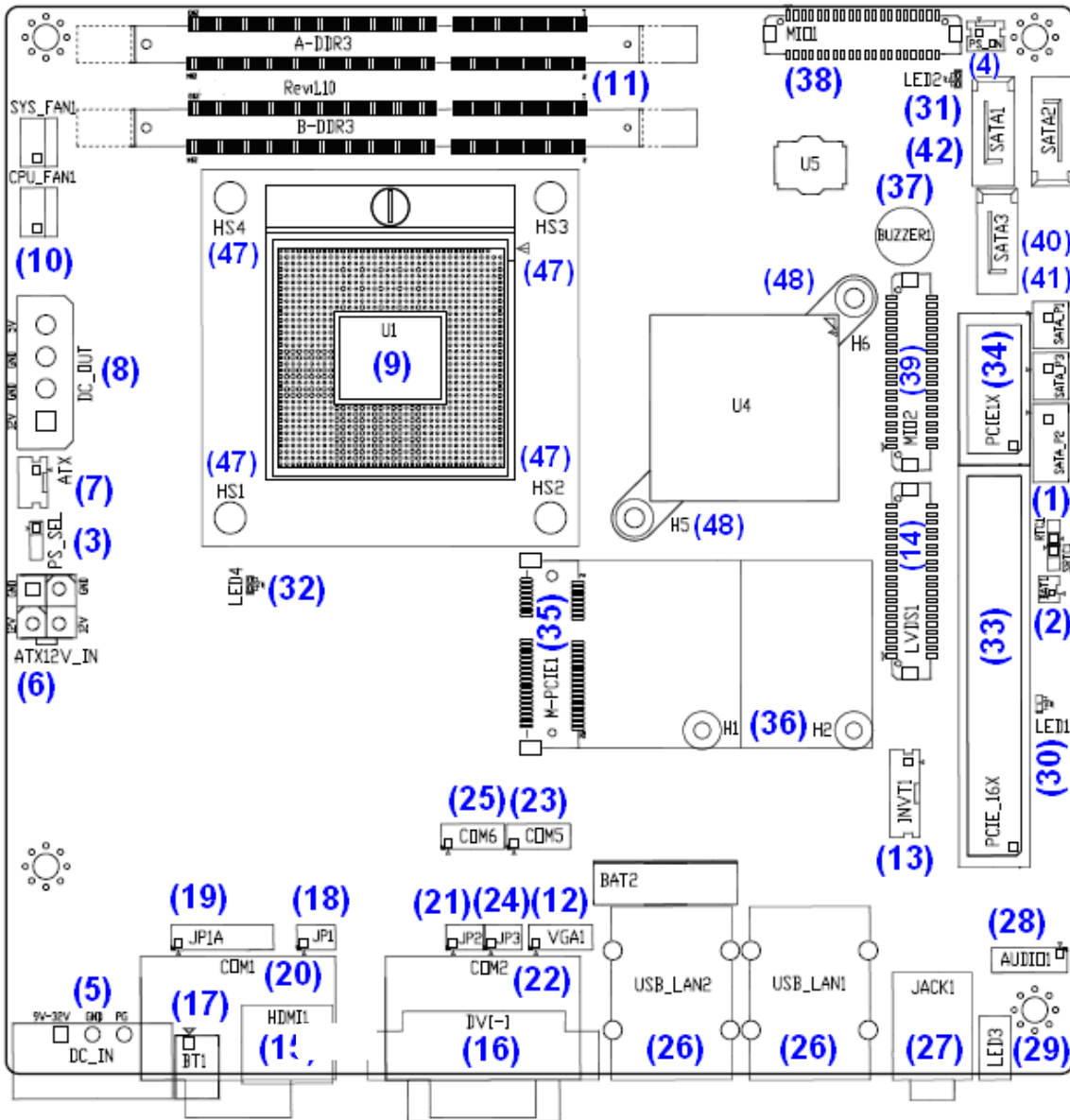

Figure 2.2: Jumpers and Connectors Location-TOP

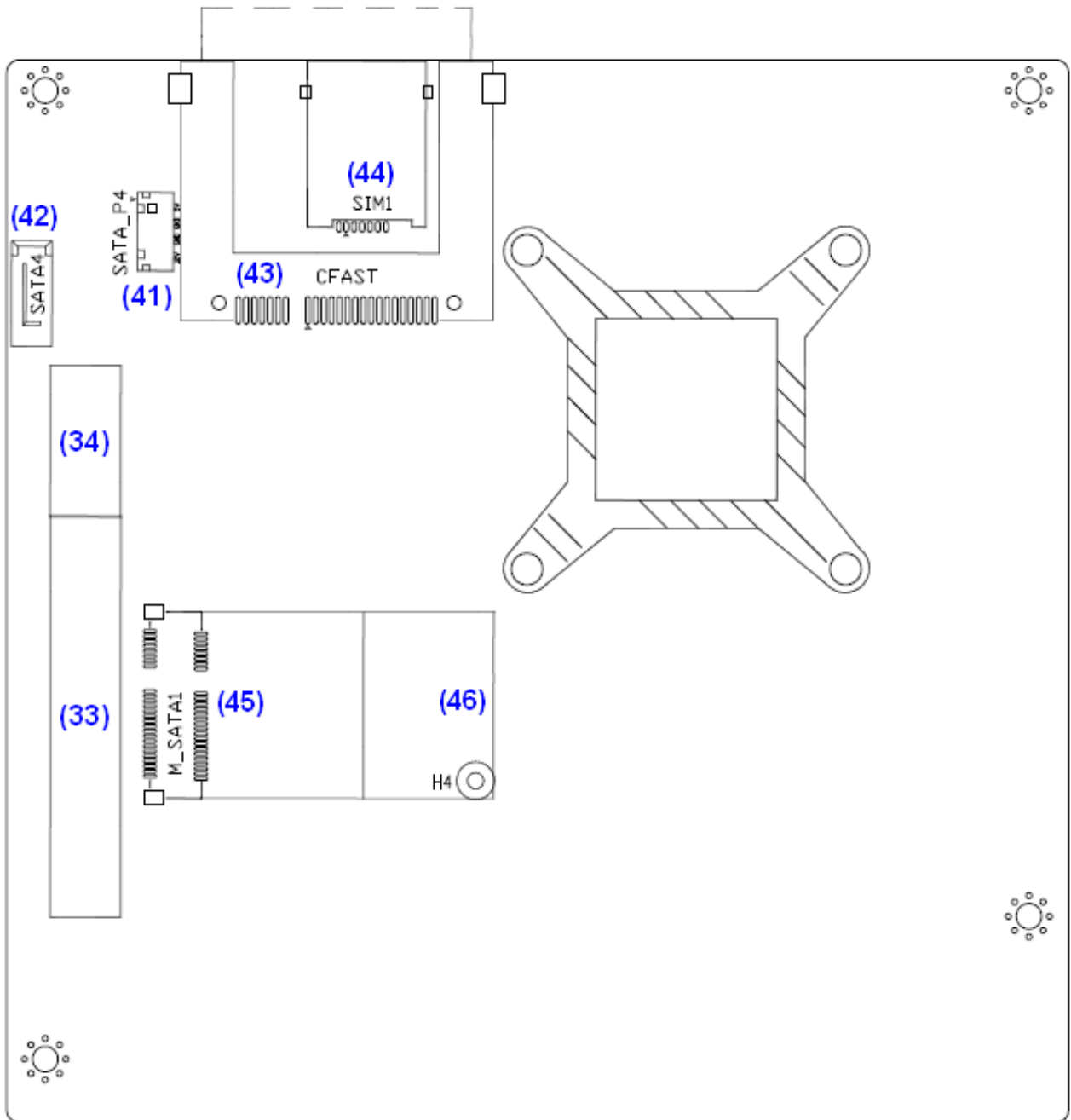

Figure 2.3: Jumpers and Connectors Location- Bottom

Specifications

Specifications	
Board Size	170mm x 170mm
CPU Support	Support Socket G2, 2nd/3rd Gen Intel Core i3/i5/i7 Processors
Chipset	Intel HM77 (ASB-M8771HB)
Memory Support	2 x SO-DIMM (204pins), up to 16GB DDRIII 1066/1333/1600MHz FSB
Graphics	Intel HD Graphics 4000
Super I/O	Winbond W83627UHG
BIOS	AMIBIOS 16M
Storage	1 x SATA2.0 Connector (SATA3) 1 x SATA2.0 Connector (SATA4 option) 2 x SATA3.0 Connector (SATA1/SATA2) 1 x MSATA Connector (option)
Ethernet	2 x PCIe GbE LAN by Intel 82574L
USB	4 x USB 2.0 stack ports for external 3 x USB 2.0 box Pin header for MIO1 4 x USB 2.0 box Pin header for MIO2 1 x USB 2.0 internal for mini PCIe
Serial	1 x RS232/422/485 port, DB9 connector for external (COM1) pin 9 w/5V/12V/Ring select 1 x RS232 port, DB9 connector for external (COM2) pin 9 w/5V/12V/Ring select 1 x RS232 header for internal (COM5) 1 x RS232 header for internal (COM6), pin 9 w/5V/12V select I/O Card TB-522 (option): 1 x 422/485 select header for internal MIO1 (COM3) 1 x RS232 header for internal MIO1 (COM4) I/O Card TB-523 (option): 1 x 422/485 select header for internal MIO1 (COM3) 1 x RS232/422/485 select header for internal MIO1 (COM4)
Digital I/O	8-bit digital I/O by Pin header by MIO2 4-bit digital Input 4-bit digital Output

Battery	Support CR2477 Li battery by 2-pin header Support CR2032 Li battery (BAT2,option)
Audio	Support Audio via Realtek ALC662 HD audio codec Support Line-out, MIC by JACK1 Support Line-in, Line-out, MIC by 2x6-pin header
Keyboard /Mouse	PS2 K/B and Mouse by MIO2 1 x PS/2 keyboard 1 x PS/2 mouse
Expansion	1 x PCI-express x16 extend by 4x30 pin socket 2 x PCI-express x1 extend by 4x10 pin socket 1 x mini-PCI-express slot 1 x CRT 2x5 Pin Header
Power Management	1 x 3-pin power input connector (Wide range DC+9V~32V) 1 x ATX Power Input (2x2Pin and 3Pin, option) DC5V/12V output by 1x4 pin Connectors
Switches and LED Indicators	Power on/off switch by TB-522 or TB-523 Reset switch by MIO2 Power LED status by MIO2 HDD LED status by MIO2
External I/O port	2 x COM Ports (COM1/COM2) 4 x USB 2.0 Ports (stack) 2 x RJ45 GbE LAN Ports 1 x DVI-I Port 1 x HDMI Port 1 x Audio Ports (Mic, Line out)
Watchdog Timer	Software programmable 1–255 second by Super I/O
Temperature	Operating: -20°C to 70°C Storage: -40°C to 85°C
Humidity	10% - 90%, non-condensing, operating
Power Consumption	12V/3.80A (Intel i5-2430M 2.4GHz Processor with 4GB DDR3) 19V/2.0A (Intel i5-2540 2.6GHz Processor with 8GB DDR3) 19V/2.2A(Intel i7-2620 2.7GHz Processor with 8GB DDR3)
EMI/EMS	Meet CE/FCC class A

2.2 Jumpers Setting and Connectors

1. RTC1/SRTC1:

(2.0mm Pitch 1X2 Pin Header) CMOS clear jumper, CMOS clear operation will permanently reset old BIOS settings to factory defaults.

RTC1/SRTC1	CMOS
Open or (RTC1Pin1-SRTC1 Pin close)	NORMAL (Default)
Close 1-2	Clear CMOS



Procedures of CMOS clear:

- Turn off the system and unplug the power cord from the power outlet.
- To clear the CMOS settings, use the jumper cap to close pins1 and 2 for about 3 seconds then reinstall the jumper clip back to pins open.
- Power on the system again.
- When entering the POST screen, press the key to enter CMOS Setup Utility to load optimal defaults.
- After the above operations, save changes and exit BIOS Setup.

2. BAT1 :

(1.25mm Pitch 1X2 box Pin Header) 3.0V Li battery is embedded to provide power for CMOS.

Pin#	Signal Name
Pin1	VBAT
Pin2	Ground

3. PS_SEL:

(2.0mm Pitch 1X3 Pin Header),DC in Power and ATX 12V_IN Power jumper setting.

PS_SEL	Mode
Close 1-2	DC in Power (Default)
Close 2-3	ATX 12V_IN Power

4. PS_ON:

(2.0mm Pitch 1X2 Pin Header),ATX Power and Auto Power on jumper setting.

PS_ON	Mode
Close 1-2	Auto Power on (Default)
Open 1-2	ATX Power

5. DCIN:

(5.08mm Pitch 1x3 Pin Connector),DC9V ~ DC32V System power input connector.

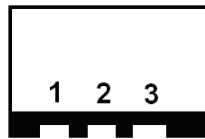

Pin#	Power Input
Pin1	DC+9V~32V
Pin2	Ground
Pin3	PG

6. ATX12V_IN (ATX Power option):

(2x2 Pin Connector), DC12V System power **input** connector.

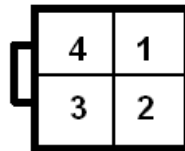

Pin#	Power input
Pin1	Ground
Pin2	Ground
Pin3	DC+12V
Pin4	DC+12V

7. ATX (ATX Power option):

(2.0mm Pitch 1X3 box Pin Header), connect PSON and 5VSB and Ground signal,support ATX Power model. **Reserved.**

Pin#	Signal Name
Pin1	ATX PSON
Pin2	ATX Ground
Pin3	ATX 5VSB

8. DC_OUT:

(2x2 Pin Connector),DC12V and DC5V System power **output** connector.

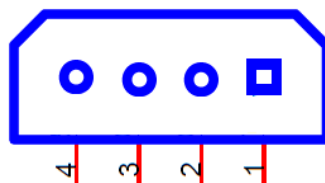

Pin#	Power output
------	--------------

Pin1	DC+12V
Pin2	Ground
Pin3	Ground
Pin4	DC+5V

9. U1:

(Socket G2), installing the 2nd GEN intel Core i3/i5/i7CPU Socket.

10. CPU_FAN1/SYS_FAN1:

(2.54mm Pitch 1x3 Pin Header), Fan connector, cooling fans can be connected directly for use. You may set the rotation condition of cooling fan in menu of BIOS CMOS Setup.



Pin#	Signal Name
1	Ground
2	VCC
3	Rotation detection



Note:

Output power of cooling fan must be limited under 5W.

11. A-DDR3/B-DDR3:

(SO-DIMM 204Pin socket), DDRIII memory socket, the socket is located at the top of the board and supports 204Pin 1.5V DDRIII 1066/1333/1600MHz FSB SO-DIMM memory module up to 16GB.

12. VGA1:

(CRT 2.0mm Pitch 2X5 Pin Header), Video Graphic Array Port, Provide 2x5Pin cable to VGA Port.

Signal Name	Pin#	Pin#	Signal Name
CRT_RED	1	2	Ground
CRT_GREEN	3	4	Ground
CRT_BLUE	5	6	Ground
CRT_H_SYNC	7	8	CRT_DDCDATA
CRT_V_SYNC	9	10	CRT_DDCCLK

13. INVT1:

(2.0mm Pitch 1x6 box Pin Header), Backlight control connector for LVDS1.

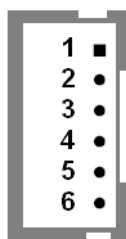

Pin#	Signal Name
1	+DC12V
2	+DC12V
3	Ground
4	Ground
5	BKLT_EN
6	BKLT_CTRL



Note:

Pin6 is backlight control signal, support DC or PWM mode, mode select at BIOS CMOS menu.

14. LVDS1:

(1.25mm Pitch 2x20 Connector), For 18/24-bit LVDS output connector, Fully supported by Intel HM77 chipset, the interface features dual channel 18/24-bit output.

Signal Name	Pin#	Pin#	Signal Name
VDD5	2	1	VDD5
Ground	4	3	Ground
VDD33	6	5	VDD33
LB_D0_N	8	7	LA_D0_N
LB_D0_P	10	9	LA_D0_P
Ground	12	11	Ground
LB_D1_N	14	13	LA_D1_N
LB_D1_P	16	15	LA_D1_P
Ground	18	17	Ground
LB_D2_N	20	19	LA_D2_N
LB_D2_P	22	21	LA_D2_P
Ground	24	23	Ground
LB_CLK_N	26	25	LA_CLK_N
LB_CLK_P	28	27	LA_CLK_P
Ground	30	29	Ground
LVLVDS_DDC_DATA	32	31	LVDS_DOC_CLK
Ground	34	33	Ground
LB_D3_N	36	35	LA_D3_N
LB_D3_P	38	37	LA_D3_P
NC	40	39	NC

- 15. HDMI1:**
(HDMI 19P Connector), High Definition Multimedia Interface connector.

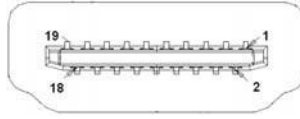

- 16. DVI-I:**
(DVI-I Connector), Digital Visual Interface-Integrated connector.

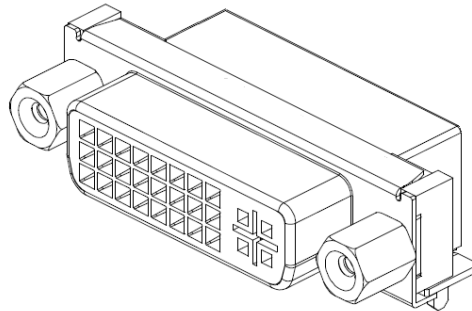

- 17. BT1:**
POWER on/off Button, They are used to connect power switch button. The two pins are disconnected under normal condition. You may short them temporarily to realize system startup & shutdown or awaken the system from sleep state.

- 18. JP1:**
(2.0mm Pitch 2x3 Pin Header), COM1 jumper setting, pin 1~6 are used to select signal out of pin 9 of COM1 port.

JP1 Pin#	Function
Close 1-2	COM1 Pin9 RI (Ring Indicator) (default)
Close 3-4	COM1 Pin9 = +5V (option)
Close 5-6	COM1 Pin9 = +12V (option)

- 19. JP1A:**
(2.0mm Pitch 2x8 Pin Header), COM1 jumper setting, it provides selectable RS232 or RS422 or RS485 serial signal output.

Function	JP1A Pin#
RS232 (Default)	Close: Pin1-3, Pin2-4, Pin7-9, Pin8-10, Pin13-14
RS422 (option)	Close: Pin3-5, Pin4-6, Pin9-11, Pin10-12, Pin17-18
RS485 (option)	Close: Pin3-5, Pin4-6, Pin9-11, Pin10-12, Pin15-16

20. COM1:

(Type DB9),Rear serial port, standard DB9 Male serial port is provided to make a direct connection to serial devices.

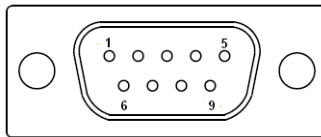

RS232 (Default):	
Pin#	Signal Name
1	DCD# (Data Carrier Detect)
2	RXD (Received Data)
3	TXD (Transmit Data)
4	DTR (Data Terminal Ready)
5	Ground
6	DSR (Data Set Ready)
7	RTS (Request To Send)
8	CTS (Clear To Send)
9	JP1 select Setting (RI/5V/12V)

RS422 (option):	
Pin#	Signal Name
1	422_R+
2	422_R-
3	422_T-
4	422_T+
5	Ground
6	NC
7	NC
8	NC
9	NC

RS485 (option):	
Pin#	Signal Name
1	NC
2	NC
3	485-
4	485+
5	Ground
6	NC
7	NC
8	NC
9	NC

21. JP2:

(2.0mm Pitch 2x3 Pin Header), COM2 jumper setting, pin 1~6 are used to select signal out of pin 9 of COM2 port.

JP2 Pin#	Function
Close 1-2	COM2 Pin9 RI (Ring Indicator) (default)
Close 3-4	COM2 Pin9=+5V (option)
Close 5-6	COM2 Pin9=+12V (option)

22. COM2:

(Type DB9), Rear serial port, standard DB9 Male serial port is provided to make a direct connection to serial devices.

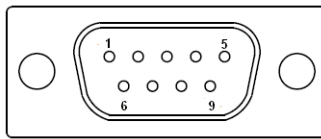

Pin#	Signal Name
1	DCD# (Data Carrier Detect)
2	RXD (Received Data)
3	TXD (Transmit Data)
4	DTR (Data Terminal Ready)
5	Ground
6	DSR (Data Set Ready)
7	RTS (Request To Send)
8	CTS (Clear To Send)
9	JP2 select Setting (RI/5V/12V)

23. COM5:

(2.0mm Pitch 2X5 Pin Header), COM5 Port, standard RS232 ports are provided. They can be used directly via COM cable connection.

Signal Name	Pin#	Pin#	Signal Name
DCD	1	2	RXD
TXD	3	4	DTR
Ground	5	6	DSR
RTS	7	8	CTS
RI	9	10	NC

24. JP3:

(2.0mm Pitch 1x3 Pin Header) COM6 setting jumper, pin 1~6 are used to select signal out of pin 9 of COM6 port.

JP3 Pin#	Function
----------	----------

Close 1-2	COM6 Pin9 RI (Ring Indicator) (default)	
Close 3-4	COM6 Pin9=+5V	(option)
Close 5-6	COM6 Pin9=+12V	(option)

25. COM6:

(2.0mm Pitch 2x5 Pin Header), COM6 Port, standard RS232 ports are provided. They can be used directly via COM cable connection. COM6 port is controlled by pins No.1~6 of JP3,select output Signal 5V or 12v, For details, please refer to description of **JP3**.

Signal Name	Pin#	Pin#	Signal Name
DCD	1	2	RXD
TXD	3	4	DTR
Ground	5	6	DSR
RTS	7	8	CTS
JP3 select Setting (RI/5V/12V)	9	10	NC

26. USB_LAN1/USB_LAN2:

USB4/USB5/USB12/USB13: (Double stack USB type A), Rear USB connector, it provides up to 4 USB2.0 ports, speed up to 480Mb/s.

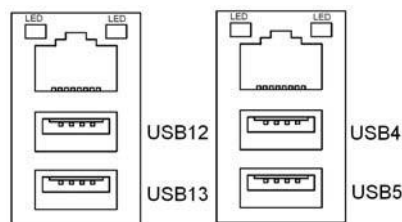

Each USB Type A Receptacle (2 Ports) Current limited value is 1.5A.

If the external USB device current exceeds 1.5A, please separate connectors into different Receptacle.

LAN1/LAN2: (RJ45 Connector), Rear LAN port, Two standard 10/100/1000M RJ-45 Ethernet ports are provided. Used Intel 82574L chipset, LINK LED (green) and ACTIVE LED (yellow) respectively located at the left-hand and right-hand side of the Ethernet port indicate the activity and transmission state of LAN.

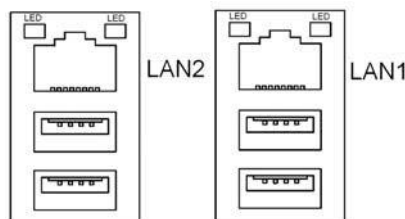

27. JACK1:

(Diameter 3.5mm Double stack Jack), HD Audio port, An onboard Realtek ALC662 codec is used to provide high quality audio I/O ports. Line Out can be connected to a headphone

or amplifier, MIC is the port for microphone input audio.

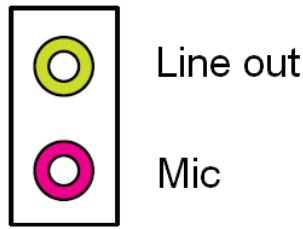

28. AUDIO1:

(2.0mm Pitch 2X6 Pin Header), Front Audio, An onboard Realtek ALC662 codec is used to provide high-quality audio I/O ports. Line Out can be connected to a headphone or amplifier. Line In is used for the connection of external audio source via a Line in cable. MIC is the port for microphone input audio.

Signal Name	Pin#	Pin#	Signal Name
SPK_OUTL_P	1	2	SPK_OUTR_P
SPK_OUTL_N	3	4	SPK_OUTR_N
FRONT_JD	5	6	LINE1_JD
LINE_IN_L	7	8	LINE-IN-R
MIC2_IN_L	9	10	MIC2-IN-R
Ground_AUD	11	12	MIC2_JD

29. LED3:

LED STATUS. Green LED for Motherboard Standby Power Good status, Yellow LED for HDD status.

30. LED1:

LED STATUS. Green LED for Motherboard Power status.

31. LED2:

LED STATUS. Green LED for Motherboard Standby Power Good status.

32. LED4:

LED STATUS. Green LED for Motherboard Power status.

33. PCIE_16X (option):

(4x30 Pin), Riser Card expansion connector. Can expand support one PCIeX16 or two PCIeX8 Signal.

ASB-M8771T: PCIE_16X connector in the top.

ASB-M8771B: PCIE_16X connector in the Bottom.

34. PCIE1X (option):

(4x10 Pin),Riser Card expansion connector.Can expand support two PCIe Signal.

ASB-M8771T: PCIE1X connector in the top.

ASB-M8771B: PCIE1X connector in the Bottom.

MODEL	PC1E16X / PCIE1X
ASB-M8771T	Top
ASB-M8771B	Bottom

35. M-PCIE1:

(Socket 52Pin),mini PCIe socket, it is located at the top, it supports mini PCIe devices with USB2.0,SIM,SMBUS and PCIe signal. MPCle card size is 30x30mm or 30 x 50.95mm.

36. H2/H1(option):

MPCIE1 SCREW HOLES, H1 for mini PCIE card (30mmx30mm) assemble. H2 for mini PCIE card (30mmx50.95mm) assemble.

37. BUZZER1:

Onboard buzzer.

38. MIO1:

(DF13-40P Connector),For expand output connector, It provides two RS232 ports or one RS485 port, three USB ports, one power led, one power button, via a dedicated cable connected to **TB-522 R1.1 MIO1**or **TB-523 R1.1 MIO1**.

Function	Signal Name	Pin#	Pin#	Signal Name	Function
COM3 RS422 or RS485	485+ / 422TX+	2	1	422RX+	COM3
	485- / 422TX-	4	3	422RX-	
	3P3V_S0	6	5	Ground	
	WAN_LED-	8	7	NC	
	5V_S5	10	9	5V_S5	
COM4	RXD4	12	11	DCD4-	COM4
	DTR4-	14	13	TXD4	
	DSR4-	16	15	Ground	
	CTS4-	18	17	RTS4-	
	5V_S5	20	19	RI4-	
USB10	5V_USB1011	22	21	5V_S5	USB9
	USB10_N	24	23	USB9_N	
	USB10_P	26	25	USB9_P	
	Ground	28	27	Ground	
	Ground	30	29	Ground	
Power LED	PWR_LED+	32	31	5V_USB1011	USB11
	PWR_LED-	34	33	USB11_N	
Power Button	MIO_PSON	36	35	USB11_P	
	Ground	38	37	Ground	
Power Auto on	AUTO_PSON-	40	39	NC	

39. MIO2:

(DF13-40P Connector), Front panel connector.

Function	Signal Name	Pin#	Pin#	Signal Name	Function
P_LED+	PWR-LED	2	1	HDD_LED	H_LED+
P_LED-	Ground	4	3	USB01_OC-	
PSON+	MIO_PSON-	6	5	USB23_OC-	
PSON-	Ground	8	7	RESET-	RESET
BUZZER-	BUZZER-	10	9	BUZZER+	BUZZER
GPIO_OUT1	PCH_GPIO68	12	11	PCH_GPIO12	GPIO_IN1
GPIO_OUT2	PCH_GPIO69	14	13	PCH_GPIO15	GPIO_IN2
GPIO_OUT3	PCH_GPIO70	16	15	PCH_GPIO58	GPIO_IN3
GPIO_OUT4	PCH_GPIO71	18	17	PCH_GPIO75	GPIO_IN4
PS2_Mouse	5V_S5_USB	20	19	Ground	PS2_K/B
	PS2_MSDATA	22	21	PS2_KBDATA	
	PS2_MSCLK	24	23	PS2_KBCLK	
USB3	5V_S5_USB	26	25	5V_S5_USB	USB2
	USB3_N	28	27	USB2_N	
	USB3_P	30	29	USB2_P	
	Ground	32	31	Ground	
USB1	5V_S5_USB	34	33	5V_S5_USB	USB0
	USB1_N	36	35	USB0_N	
	USB1_P	38	37	USB0_P	
	Ground	40	39	Ground	

Pin1- Ground: **HDD LED**, They are used to connect hard disk activity LED. The LED blinks when the hard disk is reading or writing data.

Pin2- Pin4: **POWER LED**, They are used to connect power LED. When the system is powered on or under S0/S1 state, the LED is normally on, when the system is under S4/S5 state, the LED is off.

Pin3: **USB01 OC-**, "USB01_OC-" Signal.

Pin5: **USB23 OC-**, "USB23_OC-" Signal.

Pin7- Ground: **RESET Button**, They are used to connect reset button. The two pins are disconnected under normal condition. You may short them temporarily to realize system reset.

Pin6- Pin8: **POWER on/off Button**, They are used to connect power switch button. The two pins are disconnected under normal condition. You may short them temporarily to realize system startup & shutdown or awaken the system from sleep state.

Pin9- Pin10: **BUZZER**, They are used to connect an external buzzer.

Pin11~Pin18: **GPIO IN/GPIO OUT**, General-purpose input/output port, it provides a group of self-programming interfaces to customers for flexible use.

Pin19~Pin24: **PS2 KB/MS**, PS/2 keyboard and mouse port, the port can be connected to PS/2 keyboard and mouse via a dedicated cable for direct used.

Pin25~40: **USB0/USB1/USB2/USB3**, Front USB connector, it provides 4 USB ports via a dedicated USB cable, speed up to 480Mb/s.



Note:

When connecting LEDs and buzzer and GPIO and USB, pay special attention to the signal polarity. Make sure that the connector pins have a one-to-one correspondence with chassis wiring, or it may cause boot up failure.

40. SATA_P1/SATA_P3:

(2.5mm Pitch 1x2 box Pin Header), Two onboard 5V output connectors are reserved to provide power for SATA devices.

Pin#	Signal Name
1	+DC5V
2	Ground



Note:

Output current of the connector must not be above 1A.

41. SATA_P2/SATA_P4:

(2.5mm Pitch 1x4 box Pin Header), Two onboard 5V and 12V output connectors are reserved to provide power for SATA devices.

SATA_P2 (2Pin or 4Pin)	
Pin#	Signal Name
1	+DC5V
2	Ground
3	Ground (NC)
4	+DC12V (NC)
SATA_P4 (option):	
Pin#	Signal Name
1	+DC5V (NC)
2	Ground (NC)
3	Ground (NC)
4	+DC12V (NC)



Note:

Output current of the connector must not be above 1A.

42. SATA1/SATA2/SATA3/SATA4:

(SATA 7P), SATA Connectors, Four SATA connectors are provided, SATA3 and SATA4 transfer speed up to 3.0Gb/s, SATA1 and SATA2 transfer speed up to 6.0Gb/s. RAID controller supporting RAID 0/1/5/10.

Position	Function	Color
SATA1	SATA3.0	White or Blue
SATA2	SATA3.0	White or Blue
SATA3	SATA2.0	black
SATA4	SATA2.0	black (NC)

43. N/A

44. N/A

45. M_SATA1 (option):

(50.95mmx30mm Socket 52Pin), mSATA socket, it is located at the top, it supports mini PCI-e devices with LPC bus, **B2 mSATA bus** for flash disk signal.

46. H3/H4 (option):

M_SATA1 SCREW HOLES.

H3 and H4 for mini MSATA card (50.95mmx30mm Socket 52 Pin) assemble.

47. HS1/HS2/HS3/HS4(CPU SCREW HOLES):

CPU FAN SCREW HOLES, Four screw holes for fixed CPU Cooler assemble.

48. H5/H6:

U4 SCREW HOLES.

49. TB-526P1:

TB-526P1 connect to ASB-M8771B PCIE1X connector, PCIE1X is located at the Bottom, It provides one PCI slot.

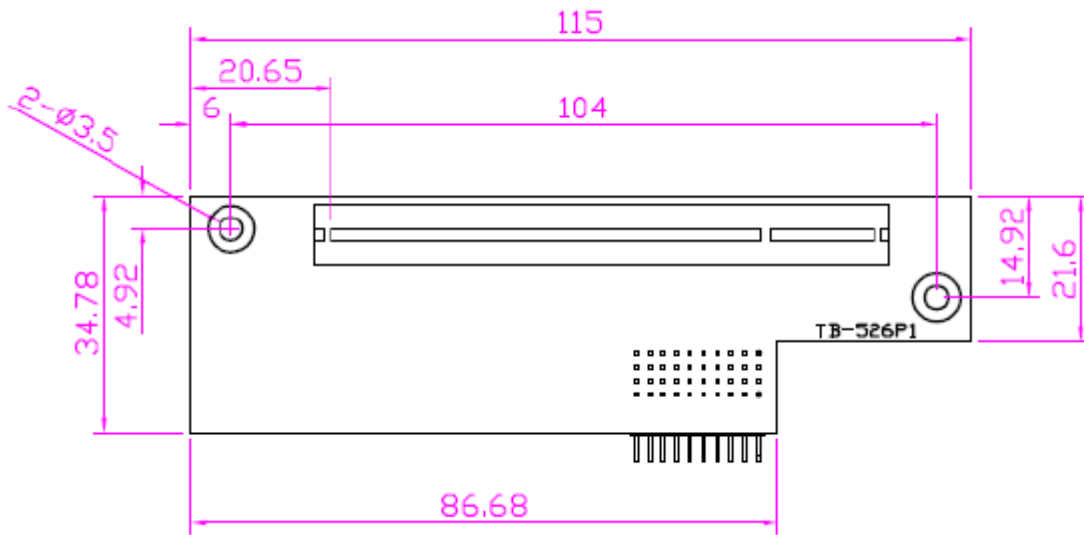

3.1 Operations after POST Screen

After CMOS discharge or BIOS flashing operation, Press [Delete] key to enter CMOS Setup.



After optimizing and exiting CMOS Setup, the POST screen displayed for the first time is as follows and includes basic information on BIOS, CPU, memory, and storage devices.

3.2 BIOS Setup Utility

Press [Delete] key to enter BIOS Setup utility during POST, and then a main menu containing system summary information will appear.

Aptio Setup Utility – Copyright (C) 2012 American Megatrends, Inc.					
Main	Advanced	Chipset	Boot	Security	Save & Exit
System Language	[English]				Choose the system Default language
System Date	[Tue 01/01/2009]				
System Time	[00:00:08]				
Access Level	Administrator				
BIOS Information					→←: Select Screen ↑↓ : Select Item Enter: Select +/- : Change Opt. F1 : General Help F2: Previous Values F3:Optimized Defaults F4:Save and Exit ESC Exit
Project Version	L8771V07	X64			
Build Date and Time	04/03/2013	01:51:14			
Processor Information					
Processor Code Name	Ivy Bridge				
Brand String	Intel (R) core (TM) I3-311				
Frequency	2400 MHz				
Number of Processors	2Core(S) / 4Thread(S)				
Total Memory	2048 MB (DDR3)				
Memory Frequency	1067 Mhz				
PCH information					
PCH Code Name	Panther Point				
Stepping	04/C1				
Version 2.15.1227. Copyright (C) 2012 American Megatrends , Inc.					

3.3 Main Settings

System Time:

Set the system time, the time format is:

Hour : 0 to 23

Minute : 0 to 59

Second : 0 to 59

System Date:

Set the system date, the date format is:

Day: Note that the 'Day' automatically changes when you set the date.

Month: 01 to 12

Date: 01 to 31

Year: 1998 to 2099

3.4 Advanced Settings

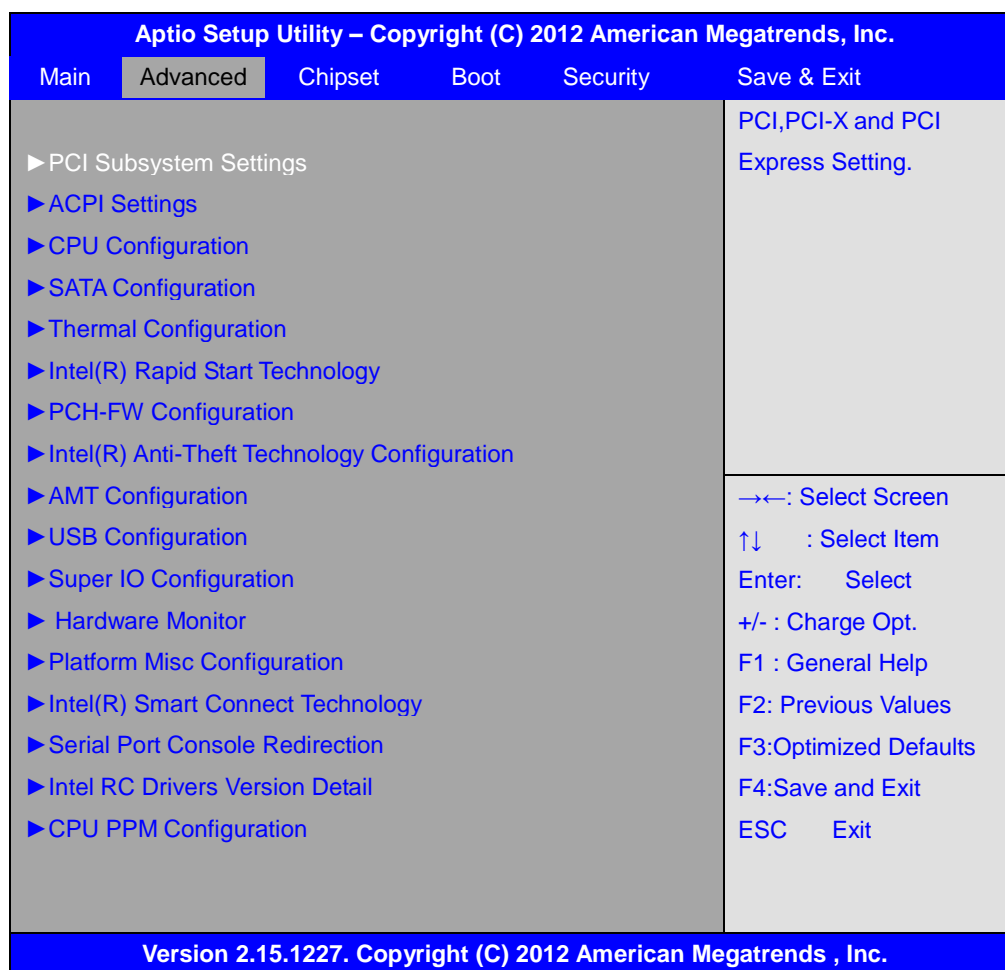

3.4.1 PCI Subsystem Settings

PCI Bus Driver Versio V2.05.02

**PCI 64bit Resources Handling:
Above 4G Decoding**

[Disabled]
[Enabled]

**PCI Common Settings:
PCI Latency Timer:**

[32 PCI Bus Clocks]
[64 PCI Bus Clocks]
[96 PCI Bus Clocks]
[128 PCI Bus Clocks]
[160 PCI Bus Clocks]
[192 PCI Bus Clocks]
[224 PCI Bus Clocks]
[248 PCI Bus Clocks]

VGA Palette snoop:

PERR# Generation: [Disabled]
[Enabled]

SERR# Generation: [Disabled]
[Enabled]

SERR# Generation: [Disabled]
[Enabled]

PCI Express Device Settings:

3.4.2 ACPI Settings

Enable ACPI Auto Configuration:

[Disabled]
[Enabled]

Enable Hibernation:

[Enabled]
[Disabled]

ACPI Sleep State:

[Both S1 and S3 avai...]
[Suspend Disabled]
[S1 only (CPU Stop clock)]
[S3 only (Suspend to RAM)]

Lock Legacy Resources:

[Disabled]
[Enabled]

S3 Video Repost:

[Disabled]
[Enabled]

3.4.3 CPU Configuration

Socket 0 CPU Information:

Intel(R) Core(TM) i3-3110M CPU @2.40GHz
 CPU Signature 306a9
 Microcode Patch 13
 Max CPU Speed 2400 MHz
 Min CPU Speed 1200Mhz
 CPU Speed 2400 MHz
 Processor Cores 2
 Intel HT Technology Supported
 Intel VT-x Technology Supported
 Intel SMX Technology Not Supported
 64-bit Supported

Hyper-threading	[Enabled] [Disabled]
Active Processor Cores	[All] [1]
Limit CPUID Maximum:	[Disabled] [Enabled]
Execute Disable Bit:	[Enabled] [Disabled]
Intel Virtualization Technology	[Enabled] [Disabled]
Hardware Prefetcher	[Enabled] [Disabled]
Adjacent Cache Line Prefetch	[Enabled] [Disabled]
3.4.4 SATA Configuration	
SATA Controller(S):	[Enabled] [Disabled]
SATA Mode Selection:	[IDE] [AHCI] [RAID]
SATA Test Mode:	[Disabled] [Enabled]
ISRT Support	[Enabled] [Disabled]

IDE legacy / Native Mode Selection
 [Native]
 [Legacy]

Serial ATA Port 0 Empty
 Software Preserve Unknown

Serial ATA Port 1 Empty
 Software Preserve Unknown

Serial ATA Port 2 Empty
 Software Preserve Unknown

Serial ATA Port 3 Empty
 Software Preserve Unknown

Serial ATA Port 4 Empty
 Software Preserve Unknown

Serial ATA Port 5 Empty
 Software Preserve Unknown

3.4.5 Thermal Configuration

Platform Thermal Configuration

3.4.6 Intel(R) Rapid Start Technology

Intel(R) Rapid Start Technology [Disabled]

3.4.7 PCH-FW Configuration

ME FW Version N/A
 ME Firmware Mode N/A
 ME Firmware Type Full Sku Firmware
 ME Firmware SKU N/A
 MDES BIOS Status Code

[Disabled]

[Enabled]

Firmware Update Configuration

3.4.8 Intel(R) Anti-Theft Technology Configuration

3.4.9 AMT Configuration

3.4.10 USB Configuration

USB Configuration

USB Devices:

1 keyboard, 2 Hubs

Legacy USB Support: [Enabled]
[Disabled]

EHCI Hand-off: [Disabled]
[Enabled]

Port 60/64 Emulation [Enabled]
[Disabled]

USB hardware delays and time-outs:

USB transfer time-out: [20 sec]
[10 sec]
[5 sec]
[1 sec]

Device reset time-out: [20 sec]
[10 sec]
[30 sec]
[40 sec]

Device power-up delay [Auto]
[Manual]

3.4.11 Super IO Configuration

Super IO Configuration

Serial Port 1 Configuration
Serial Port 2 Configuration
Serial Port 3 Configuration
Serial Port 4 Configuration
Serial Port 5 Configuration
Serial Port 6 Configuration

3.4.12 Hardware Monitor

PC Health Status

System temperature :
+43 C CPU
temperature : +60
C System Fan Speed :
N/A
CPU Fan Speed : 6490 RPM
VCORE : +0.816V

+12V	:	+12.160 V
+3.3V	:	+3.296 V
+1.5V	:	+1.520 V
AVCC	:	+5.158 V

3.4.13 Platform Misc Configuration

3.4.14 Intel(R) Smart Connect Technology

3.4.15 Serial Port Console Redirection

3.4.16 Intel RC Drivers Version Detail

3.4.17 CPU PPM Configuration

CPU PPM Configuration

EIST

[Enabled]
[Disabled]

CPU C3 Report

[Enabled]
[Disabled]

CPU C6 report

[Enabled]
[Disabled]

CPU C7 report

[Enabled]
[Disabled]

Long duration power limit 0

Long duration maintained 0

Short duration power limit 0

ACPI T State

[Disabled]
[Enabled]

3.5 Chipset Settings

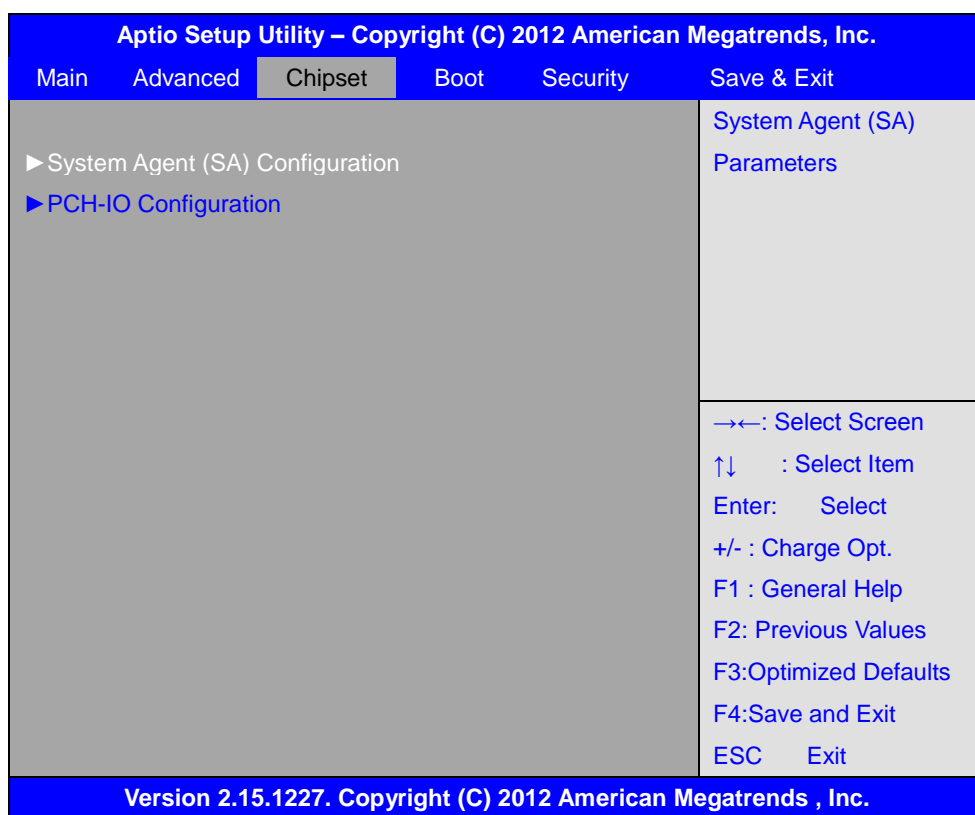

3.5.1 ► System Agent (SA) Configuration ► PCH-IO Configuration

System Agent (SA) Configuration

System Agent Bridge Name	IvyBridge
System Agent RC Version	1.6.0.0
VT-d Capability	Unsupported

► Graphics Configuration

IGFX VBIOS Version	2158
IGFX Frequency	350 MHz

Primary Display

[Auto]
[IGFX]
[PEG]
[PCI]

Internal Graphics

[Auto]
[Disabled]

GTT Size	[Enabled]
	[2MB]
	[1MB]
Aperture Size	[256MB]
	[128MB]
	[512MB]
DVMT Pre-allocated	[64MB]
	[32MB]
	[96MB]
	[128MB]
	[160MB]
	[192MB]
	[224MB]
	[256MB]
	[288MB]
	[320MB]
	[352MB]
	[384MB]
	[416MB]
	[448MB]
	[480MB]
	[512MB]
	[1024MB]
Dvmt Total Gfx Mem	[256MB]
	[128MB]
	[MAX]
GFX Low Power Mode	[Enabled]
	[Disabled]
Primary IGFX Boot Display	[VBIOS Default]
	[VGA]
	[DVI]
	[LVDS]
LCD Panel Type	[1280 X 1024 24bit 2ch]
	[640 X 480 18bit 1ch]
	[800 X 480 18bit 1ch]
	[800 X 600 18bit 1ch]

[800 X 600 24bit 1ch]
[1024 X 768 18bit 1ch]
[1024 X 768 24bit 1ch]
[1280 X 800 18bit 1ch]
[1366 X 768 18bit 1ch]
[1440 X 900 24bit 2ch]
[1600 X 900 24bit 2ch]
[1600 X 1200 24bit 2ch]
[1680 X 1050 24bit 2ch]
[16800 X 1050 24bit 2ch]
[1920 X 1080 24bit 2ch]
[2048 X 1536 24bit 2ch]

Panel Scaling

[Auto]
[Off]
[Force Scaling]

Backlight Control

[DC]
[PWM]

Backlight Logic

[Positive]
[Negaive]

Backlight Control Control Level

[Level 8]
[Level 0]
[Level 1]
[Level 2]
[Level 3]
[Level 4]
[Level 5]
[Level 6]
[Level 7]
[Level 9]
[Level 10]
[Level 11]
[Level 12]
[Level 13]
[Level 14]
[Level 15]

- ▶ DMI Configuration
- ▶ NB PCIe Configuration

PEG0 [Not Present]
 PEG0 – Gen X [Auto]
 [Gen1]
 [Gen2]
 [Gen3]

PEG ASPM
 [Auto]
 [Disabled]
 [Auto]
 [ASPM LOs]
 [ASPM L1]
 [ASPM LOsL1]

De-emphasis Control
 [-3.5 dB]
 [-6 dB]

► Memory Configuration

Memory	RC	Version
1.6.6.0		
Memory		Frequency
1067 Mhz		
Total		Memory
2048	MB	(DDR3) DIMM#0
2048	MB	(DDR3) DIMM#2
Not Present		
CAS	Latency	(tCL)
7		
Minimum delay time		
CAS to RAS (tRPmin)		7
Row Precharge (tRPmin)		7
Active to Precharge (tRPmin)		20

► GT-Power Management Control

GT Info GT2 (0X116)
 RC6 (Render Standby)
 [Enabled]
 [Disabled]
 GT overClocking Support
 [Disabled]
 [Enabled]

► PCH-IO Configuration

Intel PCH RC Version 1.6.6.0
 Intel PCH SKU Name QM77
 Intel PCH Rev ID 04/C1

PCH LAN Controller
 [Disabled]

Wark on LAN	[Enabled]
	[Enabled]
	[Disabled]
Board Capability	[SUS_PWR_DN_ACK]
	[Deepsx]
SLP_S4 Assertion Width	[4-5 Seconds]
	[1-2 Seconds]
	[2-3 Seconds]
	[3-4 Seconds]
Restore AC Power Loss	[Power off]
Set NAND Management Override	[Enabled]
	[Disabled]
► PCI Express Configuration	
PCI Express Clock Gating	[Enabled]
	[Disabled]
DMI Link ASPM Control	[LOSL1]
	[LOS]
	[Disabled]
DMI Link Extended Synch Control	[Disabled]
	[Enabled]
Subtractive Decode	[Disabled]
	[Enabled]
► PCI Express Root Port 1	
► PCI Express Root Port 2	
► PCI Express Root Port 3	
► PCI Express Root Port 4	
► PCI Express Root Port 5	
► PCI Express Root Port 6	
► PCI Express Root Port 7	
► PCI Express Root Port 8	
► USB Configuration	
► PCH Azalia Configuration	
► BIOS Security Configuration	

3.6 Boot Settings

Aptio Setup Utility – Copyright (C) 2012 American Megatrends, Inc.					
Main	Advanced	Chipset	Boot	Security	Save & Exit
Boot Configuration				Number of seconds to Wait for setup	
Setup Prompt Timeout		1			Activation key.
Bootup Numlock State		[On]			65535(0xFFFF)means
Quiet Boot		[Disabled]			Indefinite waiting.
Fast Boot		[Disabled]			
CSM16 Module Version		07.69			
Gatea20 Active		[Upon Request]			
Option ROM Messages		[Force BIOS]			→←: Select Screen
INT19 Trap Response		[Immediate]			↑↓ : Select Item
Boot Option Priorities					Enter: Select
▶ CSM parameters					+/- : Change Opt.
					F1 : General Help
					F2: Previous Values
					F3:Optimized Defaults
					F4:Save and Exit
					ESC Exit

Setup Prompt Timeout	[1]
Bootup Numlock State	[On] [off]
Quiet Boot	[Disabled] [Enabled]
Fast Boot	[Disabled] [Enabled]
CSM16 Module Verison	07.69
Gatea20 Active	[Upon Request] [Always]

Option ROM Messages

[Force BIOS]
[Keep Current]

Interrupt 19 Capture

[Immediate]
[Postponed]

Boot Option Priorities

► **CSM parameters**

3.7 Security Settings

Aptio Setup Utility – Copyright (C) 2012 American Megatrends, Inc.					
Main	Advanced	Chipset	Boot	Security	Save & Exit
Password Description				Set Administrator Password	
<p>If ONLY the Administrator's password is set, Then this only limits access to Setup and is Only asked for when entering Setup.</p> <p>If ONLY the User's password is set, then this Is a power on password and must be entered to Is a power on password and must be entered to Boot or enter Setup. In Setup the User will Have Administrator rights.</p>					
Minimum Length	3			→←: Select Screen	
Maximum Length	20			↑↓ : Select Item	
Administrator Password				Enter: Select	
User Password				+/- : Change Opt.	
				F1 : General Help	
				F2: Previous Values	
				F3:Optimized Defaults	
				F4:Save and Exit	
				ESC Exit	
Version 2.15.1227. Copyright (C) 2012 American Megatrends , Inc.					

3.7.1 Administrator Password



3.7.2 User Password



Type the password with up to 20 characters and then press <Enter> key. This will clear all previously typed CMOS passwords. You will be requested to confirm the password. Type the password again and press <Enter> key. You may press <Esc> key to abandon password entry operation.

To clear the password, just press <Enter> key when password input window pops up. A confirmation message will be shown on the screen as to whether the password will be disabled. You will have direct access to BIOS setup without typing any password after system reboot once the password is disabled.

Once the password feature is used, you will be requested to type the password each time you enter BIOS setup. This will prevent unauthorized persons from changing your system configurations.

Also, the feature is capable of requesting users to enter the password prior to system boot to control unauthorized access to your computer. Users may enable the feature in Security Option of Advanced BIOS Features. If Security Option is set to System, you will be requested to enter the password before system boot and when entering BIOS setup; if Security Option is set to Setup, you will be requested for password for entering BIOS setup.

3.8 Save & Exit Settings

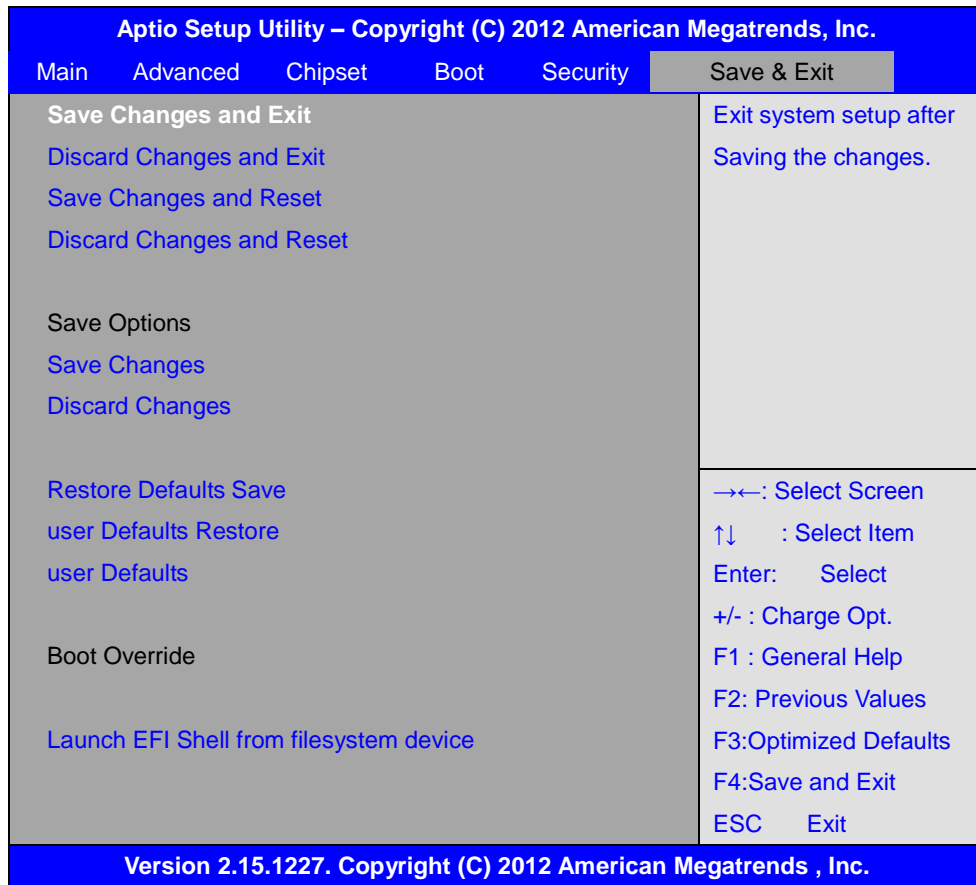

Save Changes and Exit

Save & Exit Setup save Configuration and exit ?

[Yes]

[No]

Discard Changes and Ext

Exit Without Saving Quit without saving?

[Yes]

[No]

Save Changes and Reset
 Save & reset Save Configuration and reset?
 [Yes]
 [No]

Discard Changes and Reset
 Reset Without Saving Reset without saving?
 [Yes]
 [No]

Save Changes
 Save Setup Values Save configuration?
 [Yes]
 [No]

Discard Changes
 Load Previous Values Load Previous Values?
 [Yes]
 [No]

Restore Defaults
 Load Optimized Defaults Load optimized Defaults?
 [Yes]
 [No]

Save user Defaults
 Save Values as User Defaults Save configuration?
 [Yes]
 [No]

Restore user Defaults
 Restore User Defaults Restore User Defaults?
 [Yes]
 [No]

Launch EFI Shell from filesystem device
 WARNING Not Found
 [ok]

Chapter 4 Installation of Drivers

This chapter describes the installation procedures for software and drivers under the windows XP. The software and drivers are included with the motherboard. The contents include Intel chipset driver, VGA driver, Network Adapter, Audio driver, .USB 3.0 driver, AMT driver. Installation instructions are given below.

Important Note:

After installing your Windows operating system (Windows XP), you must install first the Intel Chipset Software Installation Utility before proceeding with the installation of drivers.



4.1 Intel Chipset Driver

To install the Intel chipset driver, please follow the steps below.
Step 1: Select Chipset from the list



Follow the step-by-step installation process to install the driver.



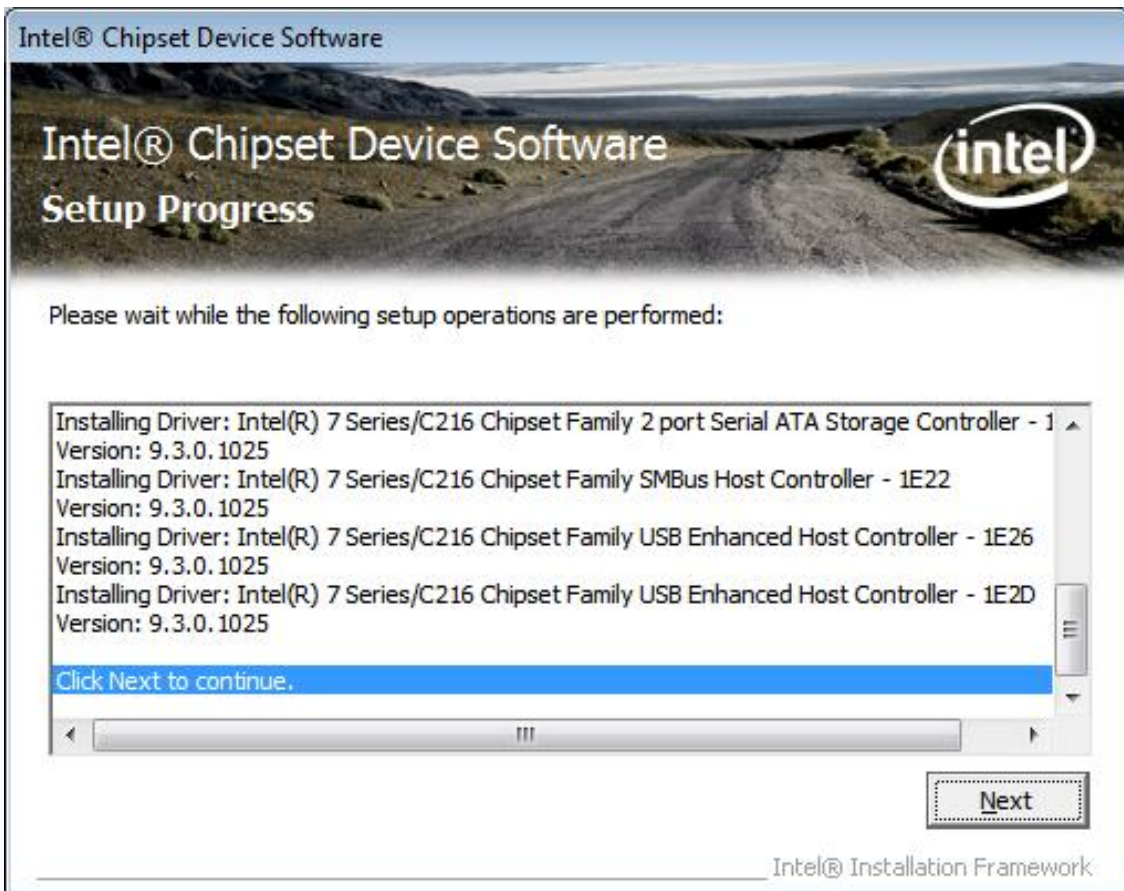
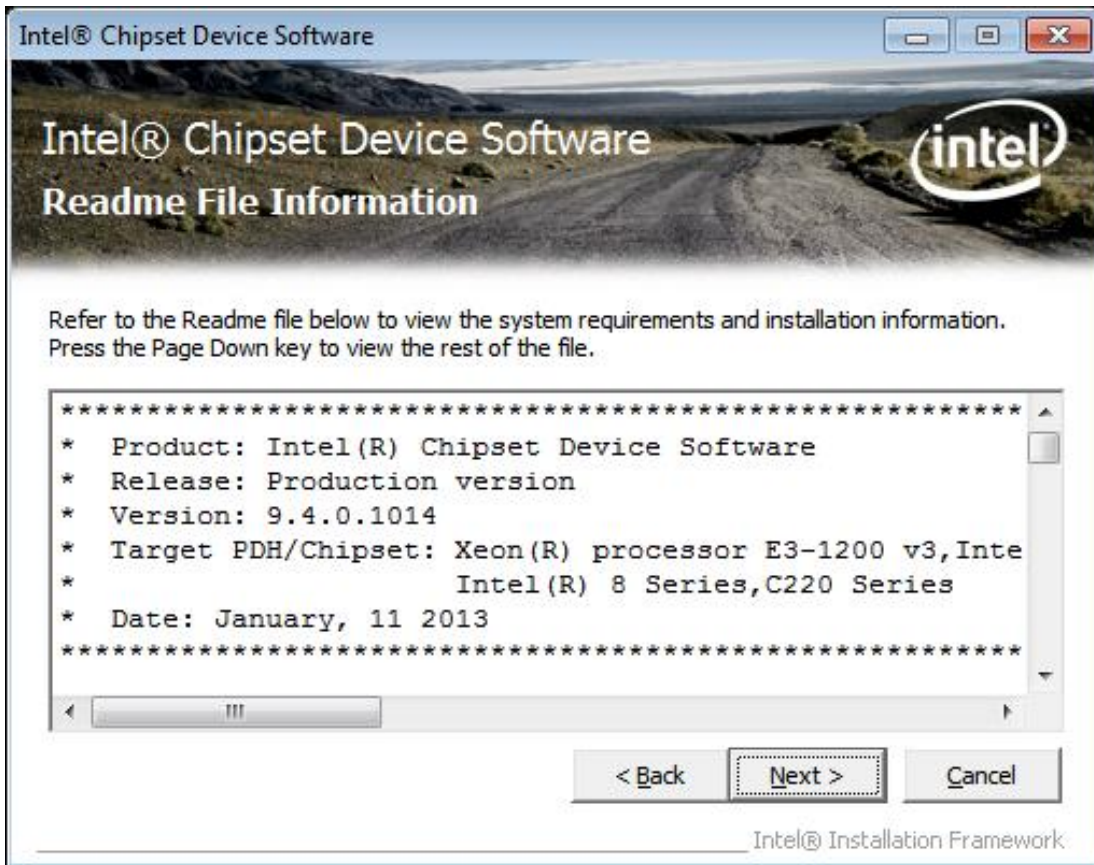

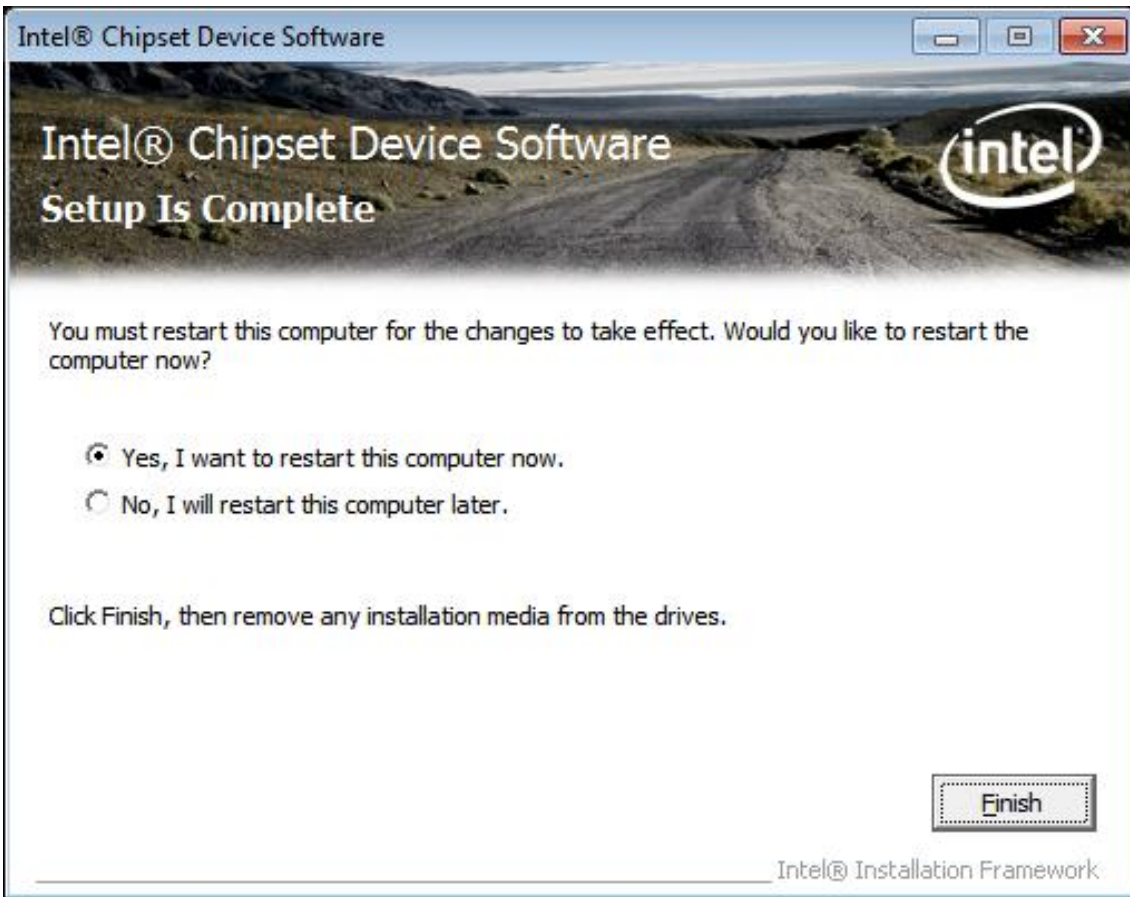

4.2 Intel VGA Chipset Driver

To install the VGA drivers, follow the steps below to proceed with the installation.

1. Click Intel VGA Chipset Driver.



Follow the step-by-step installation process to install the Graphics Media Accelerator driver.

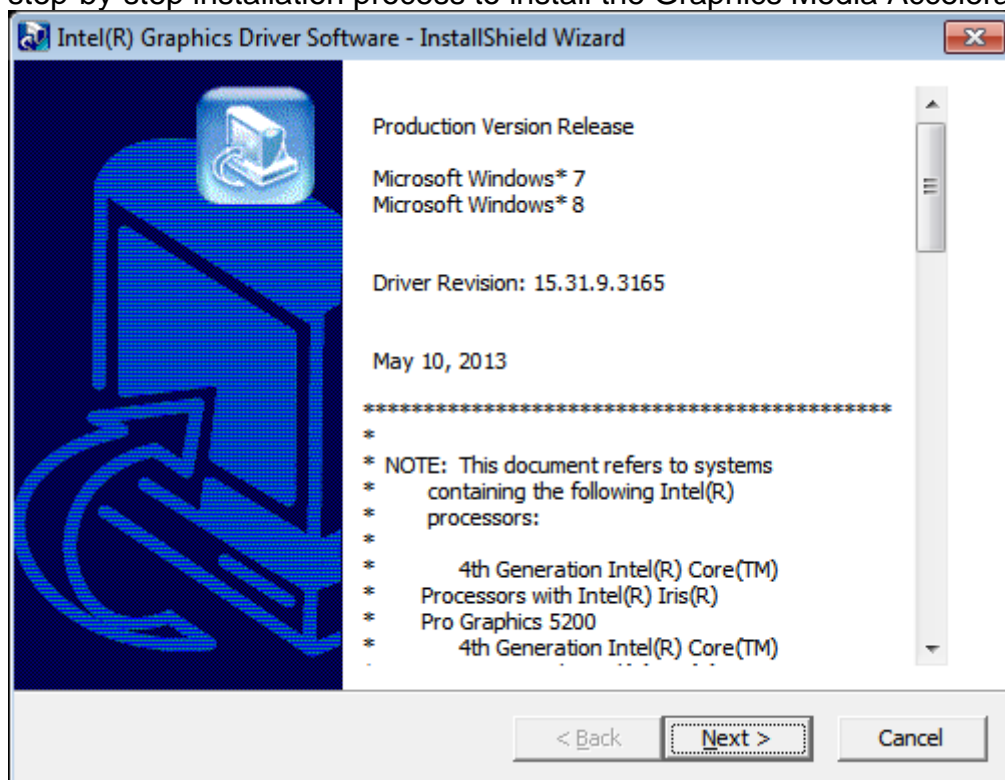

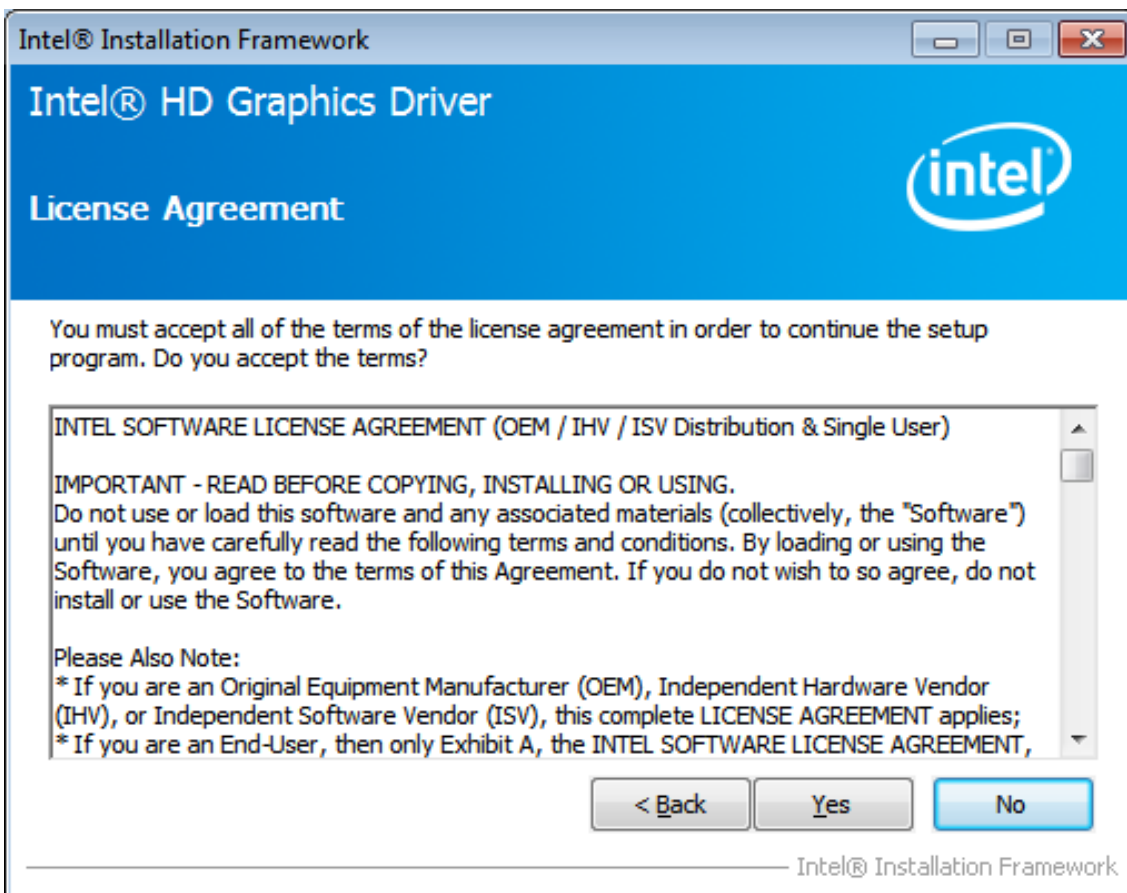
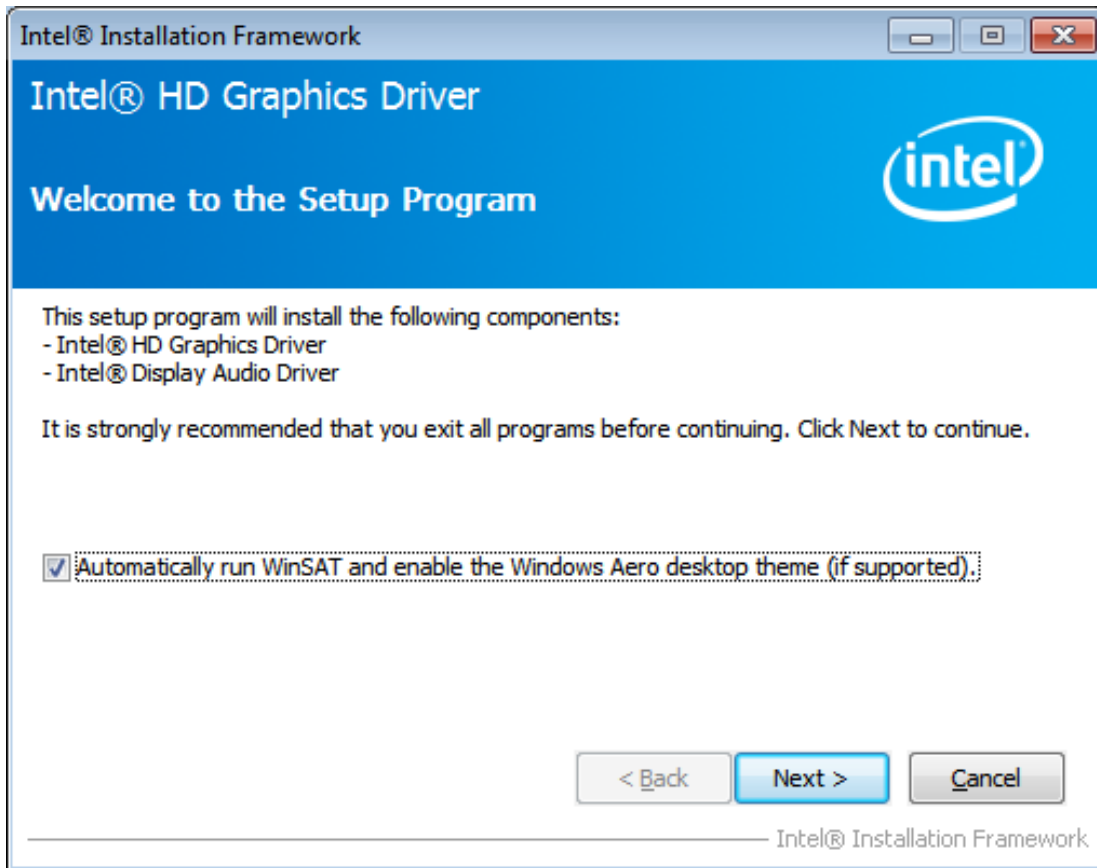

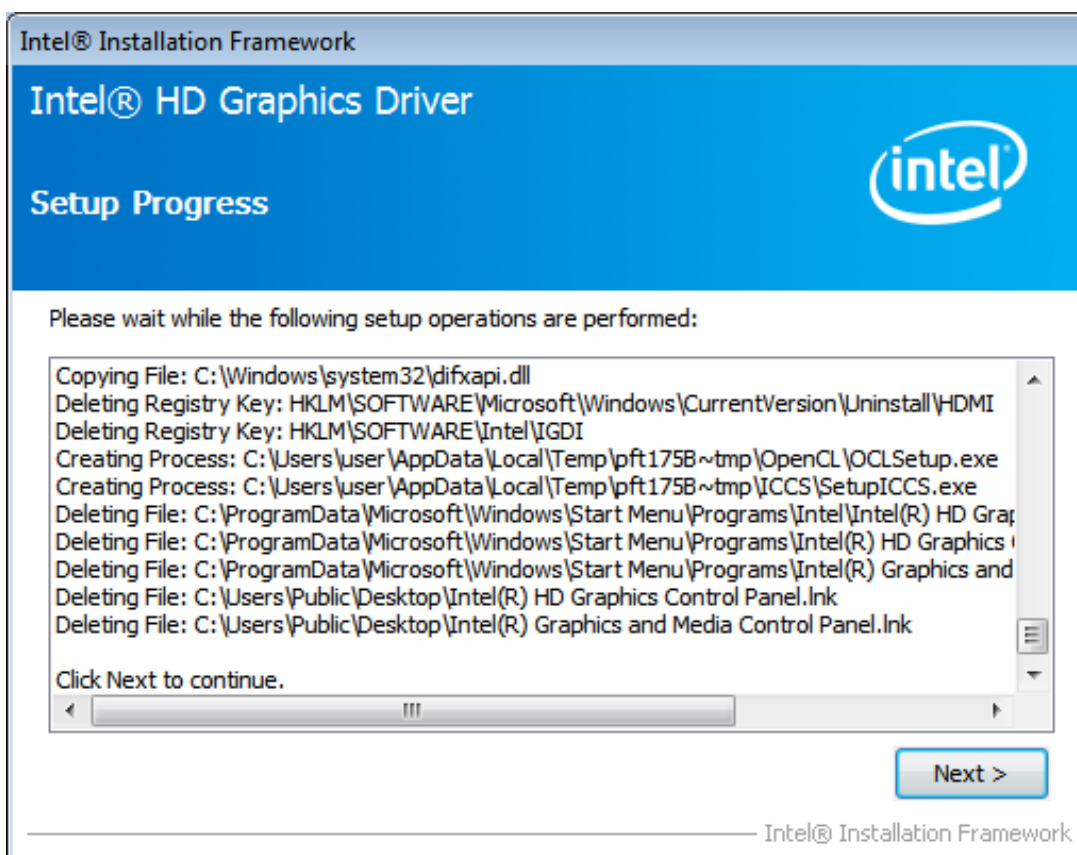
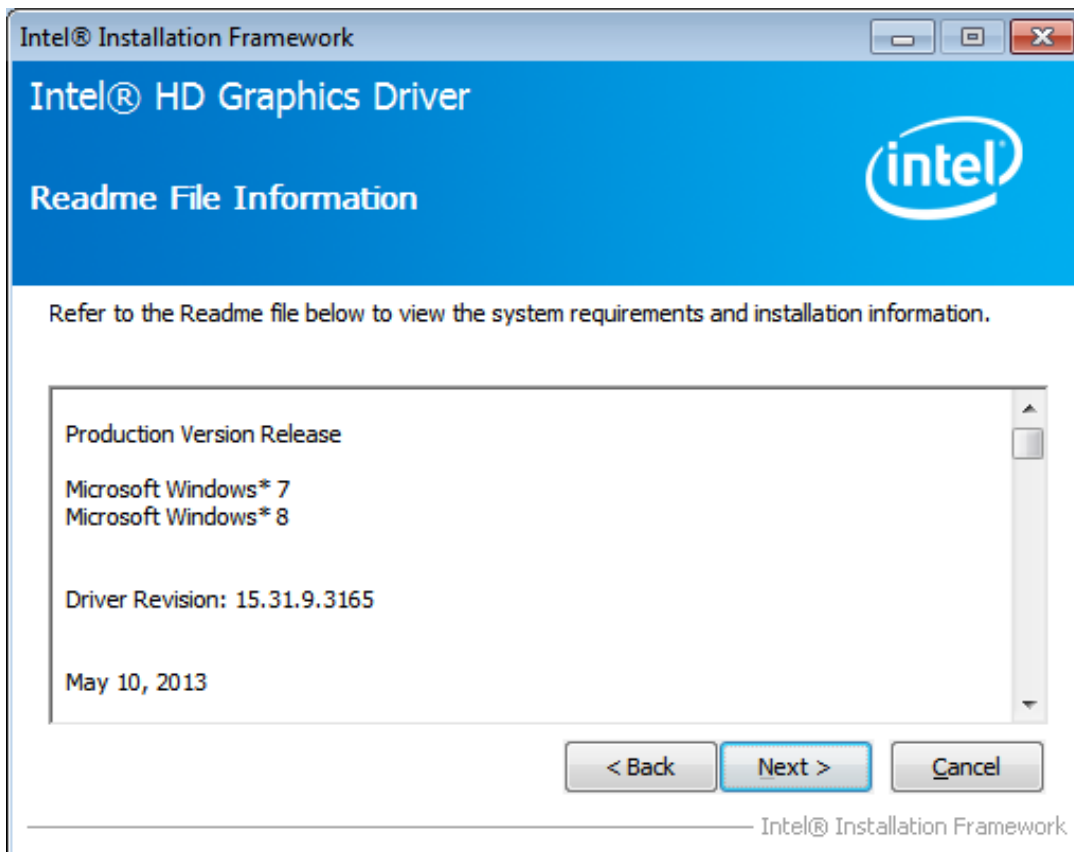

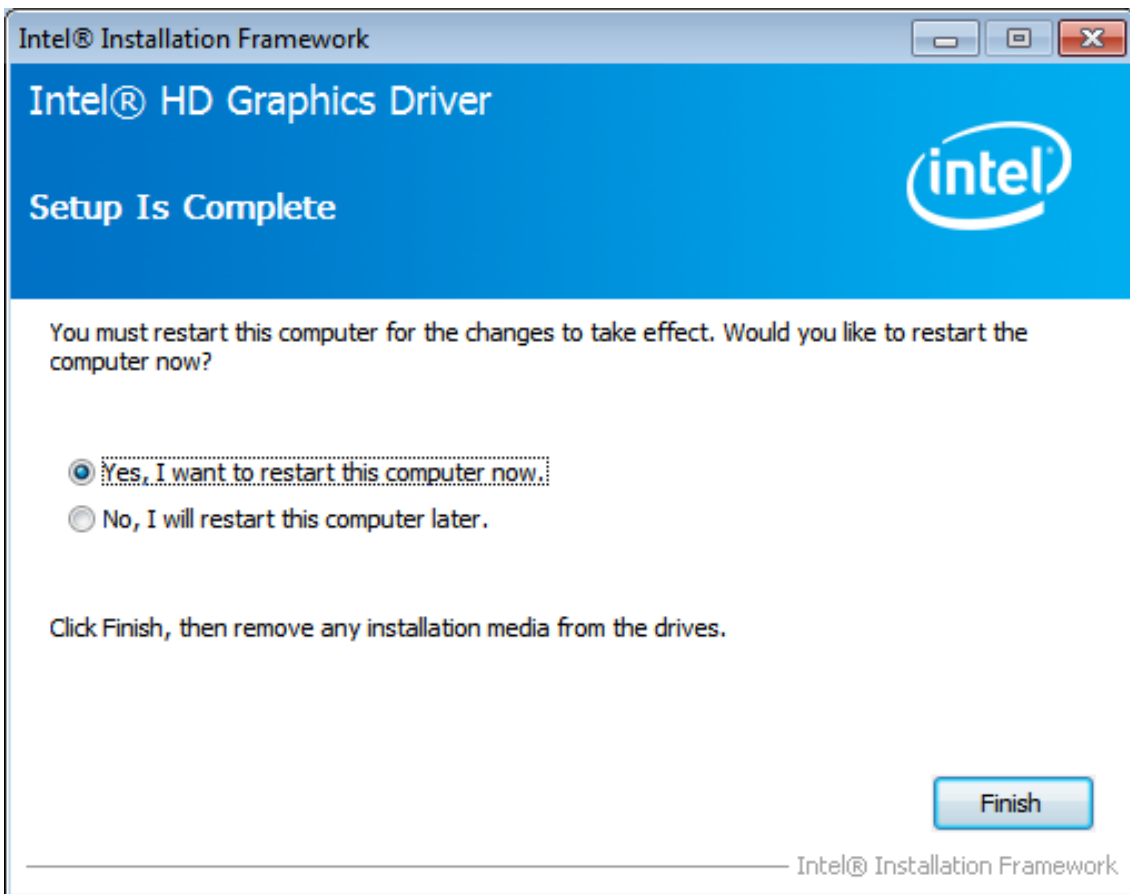

Click FINISH; A Driver Installation Complete.

4.3 Intel(R) Network Adapter Driver

To install the Intel(R) Network Adapter Driver, please follow the steps below.
Select LAN from the list



Follow the step-by-step installation process to install the LAN driver.

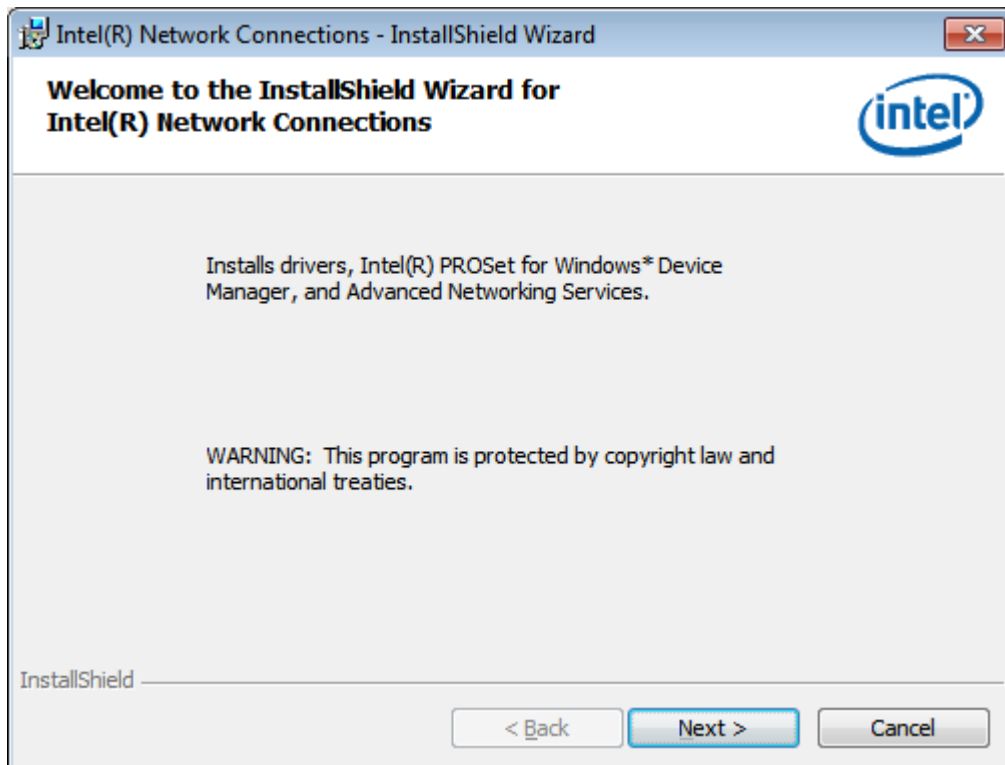

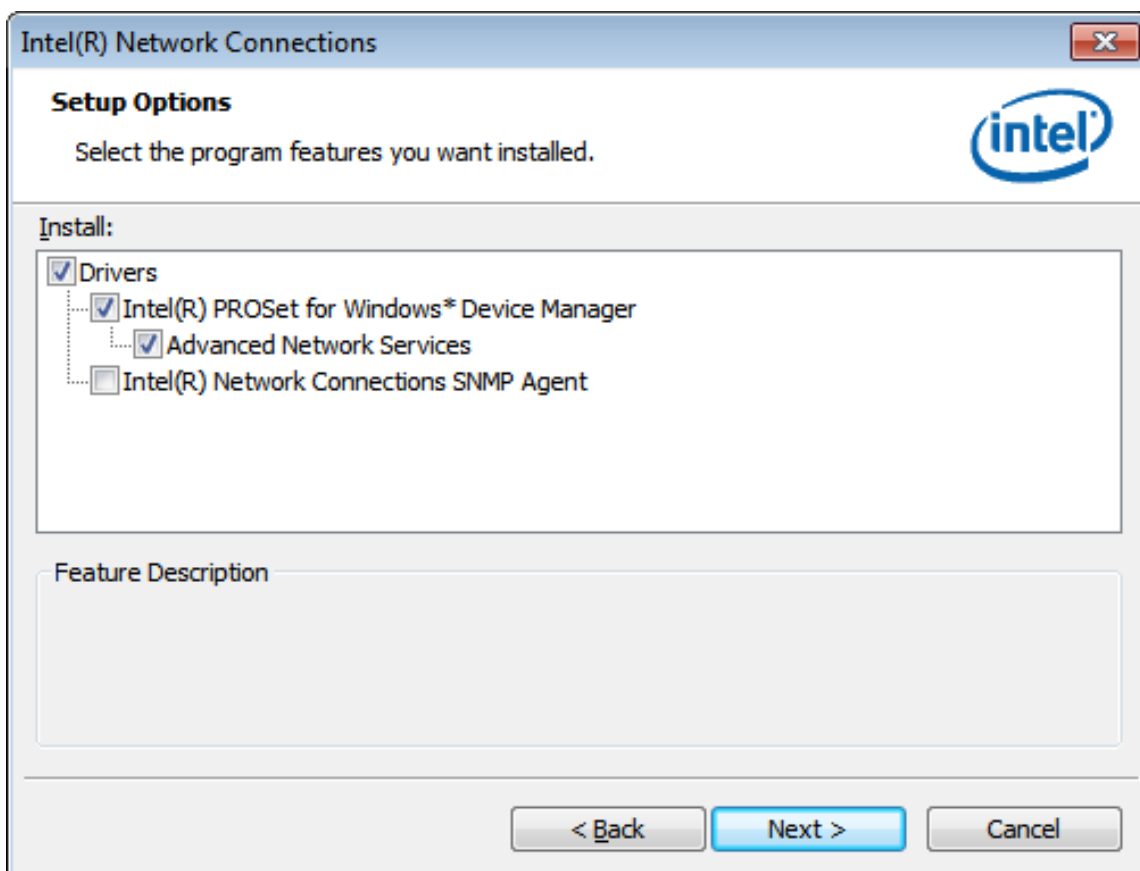
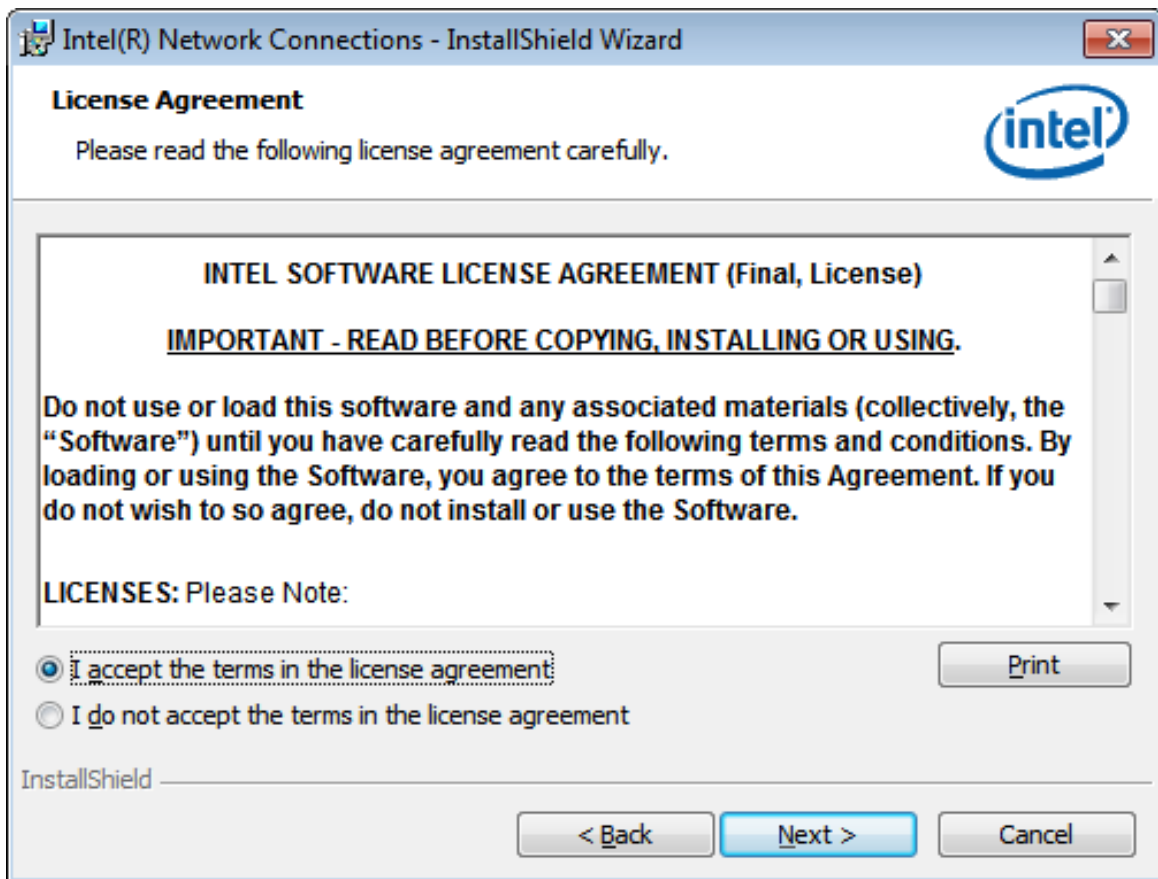

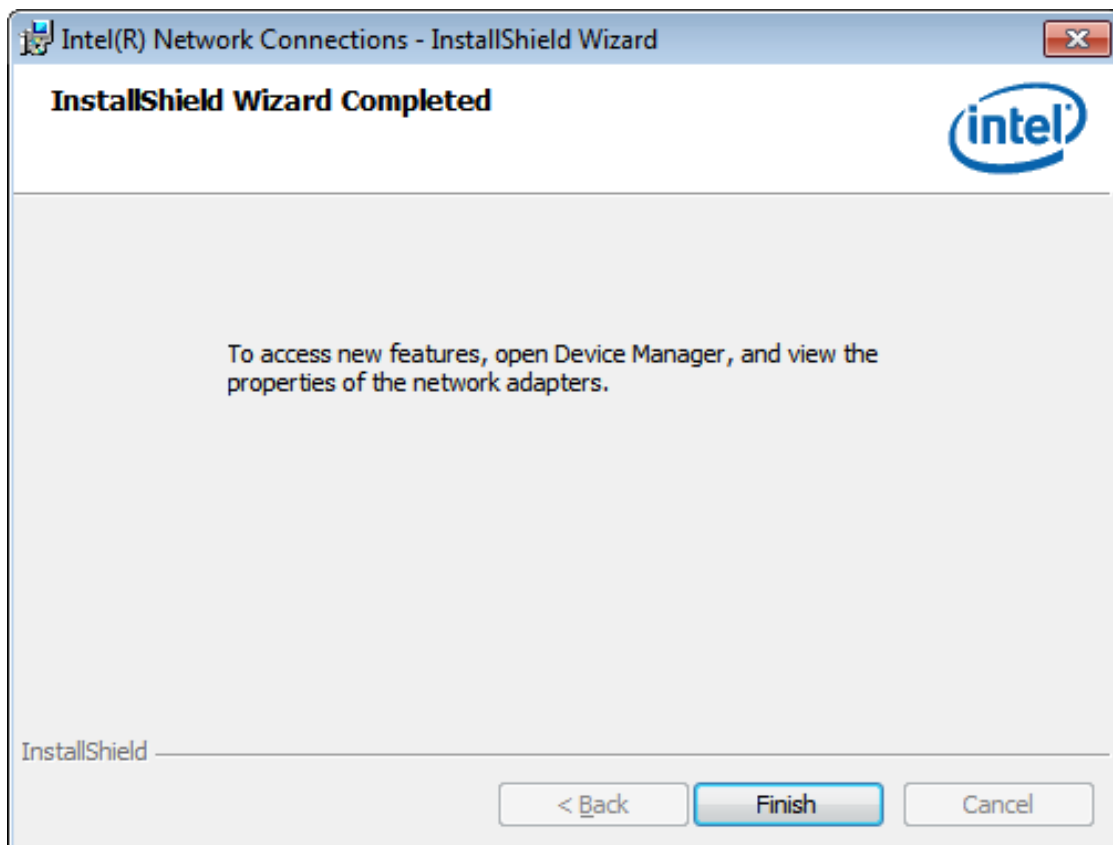
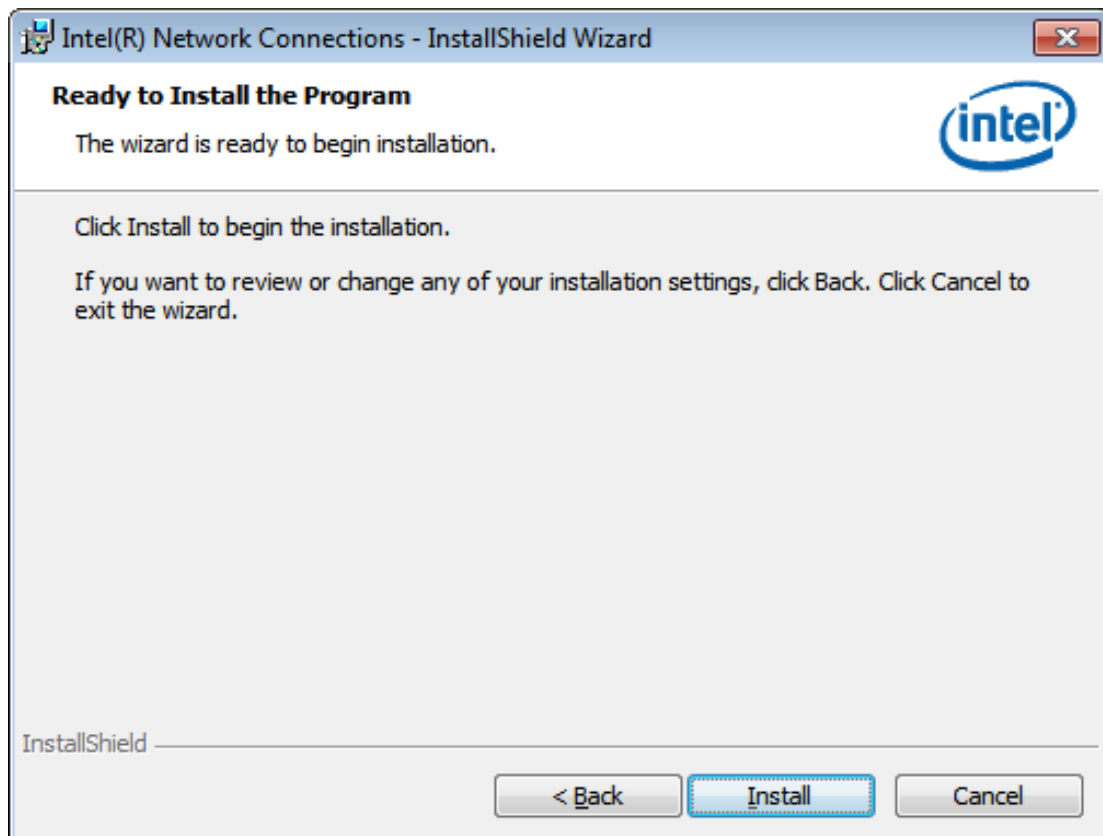

Click FINISH; A Driver Installation Complete.

4.4 Realtek Audio Driver Installation

To install the Realtek High Definition (HD) Audio driver, please follow the steps below. Select Audio from the list



Follow the step-by-step installation process to install the Realtek HD Audio driver.

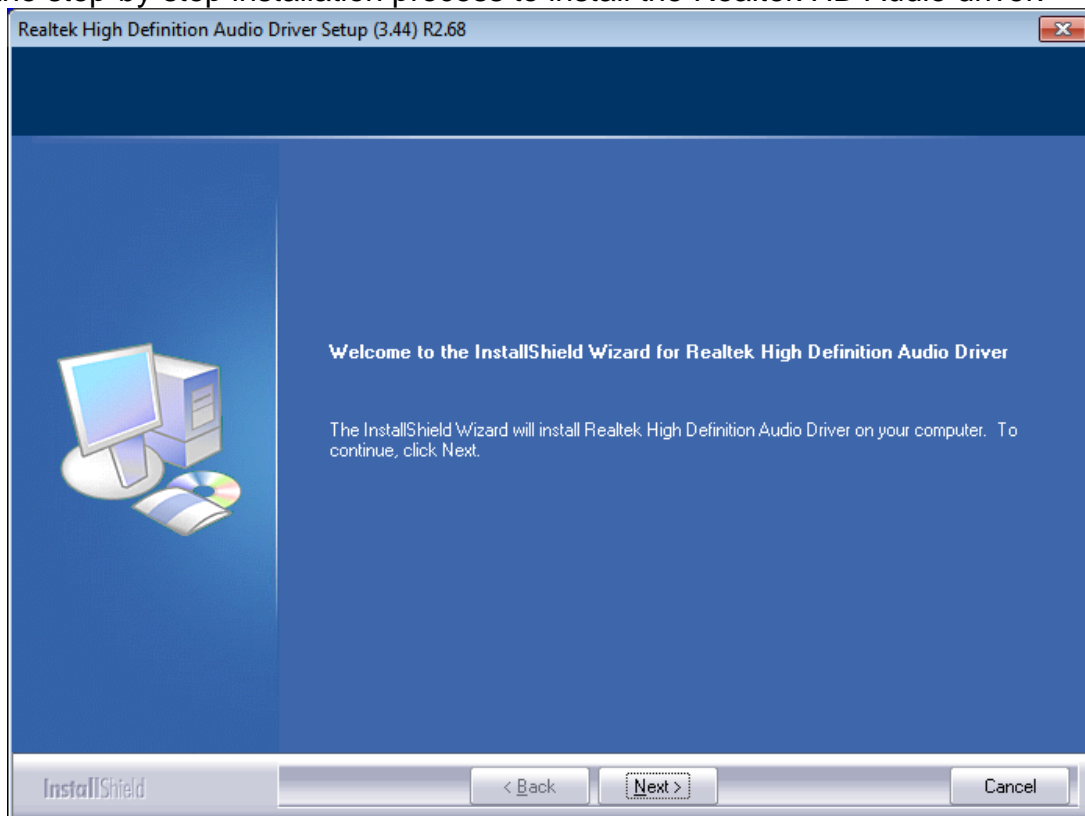

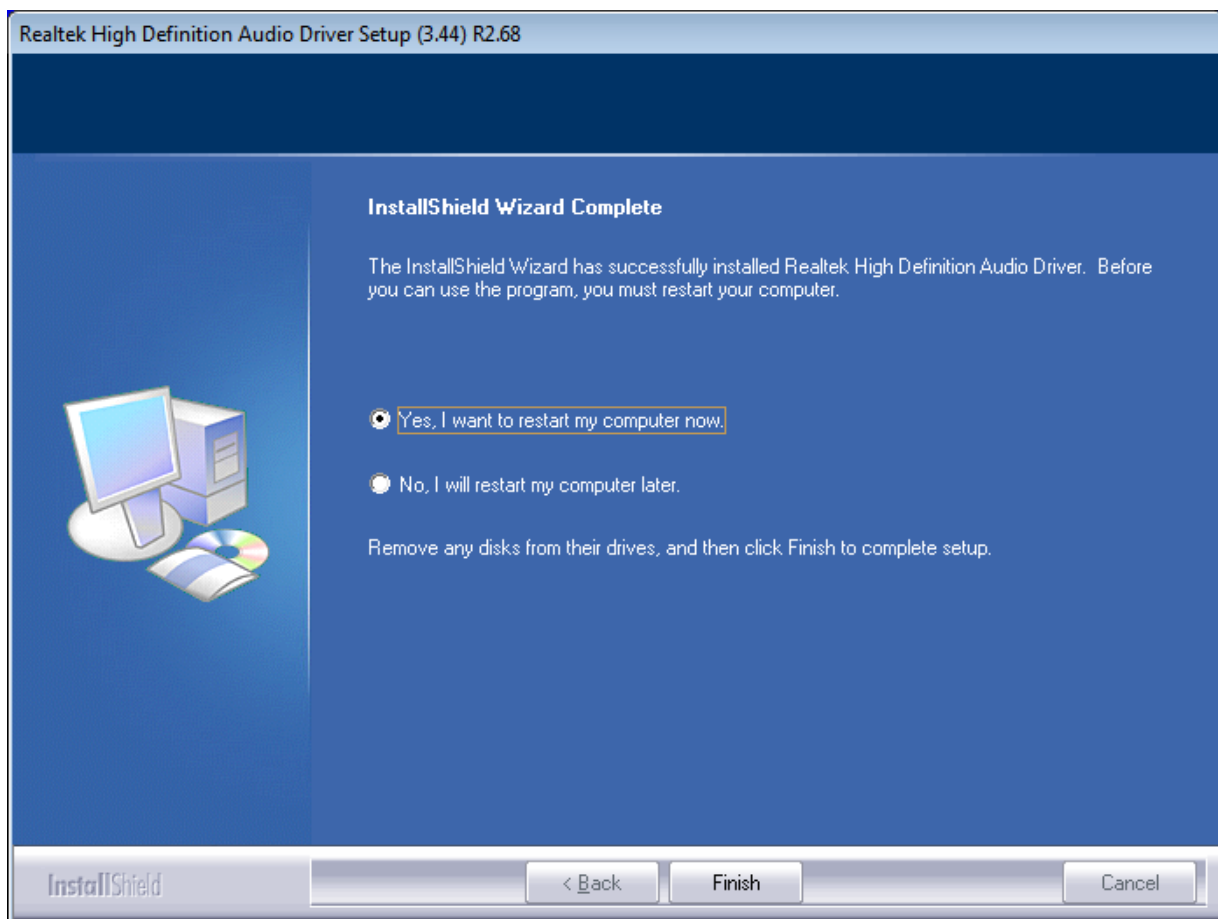

Click FINISH; A Driver Installation Complete.

4.5 Intel(R) USB 3.0 Driver Installation

To install the Intel(R) USB 3.0 Driver Service, please follow the steps below.

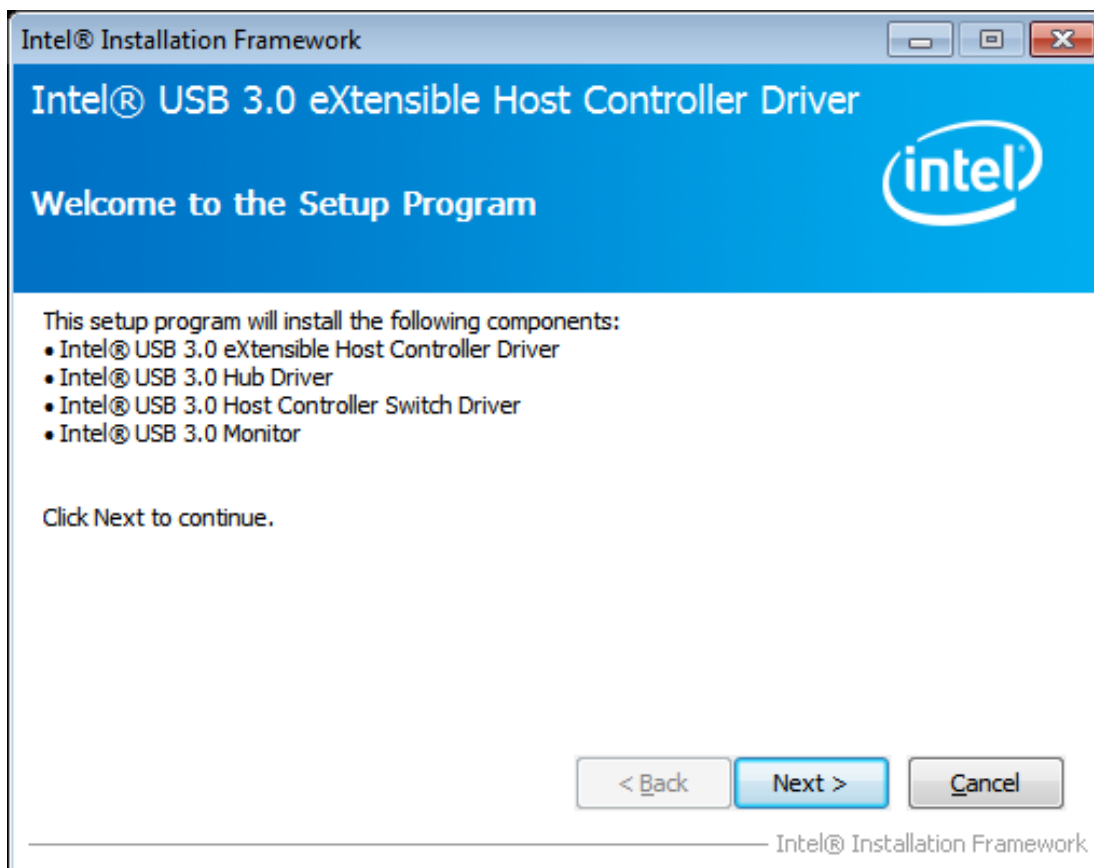

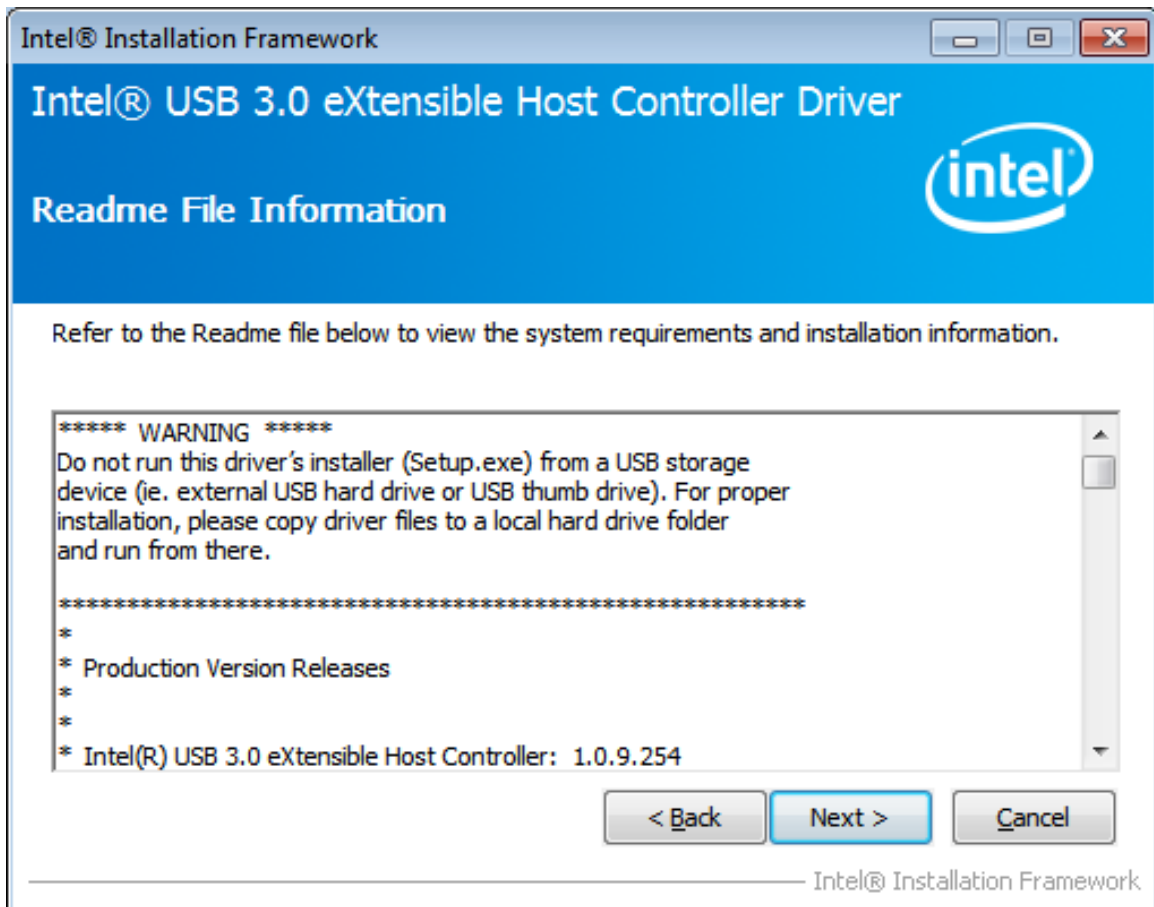
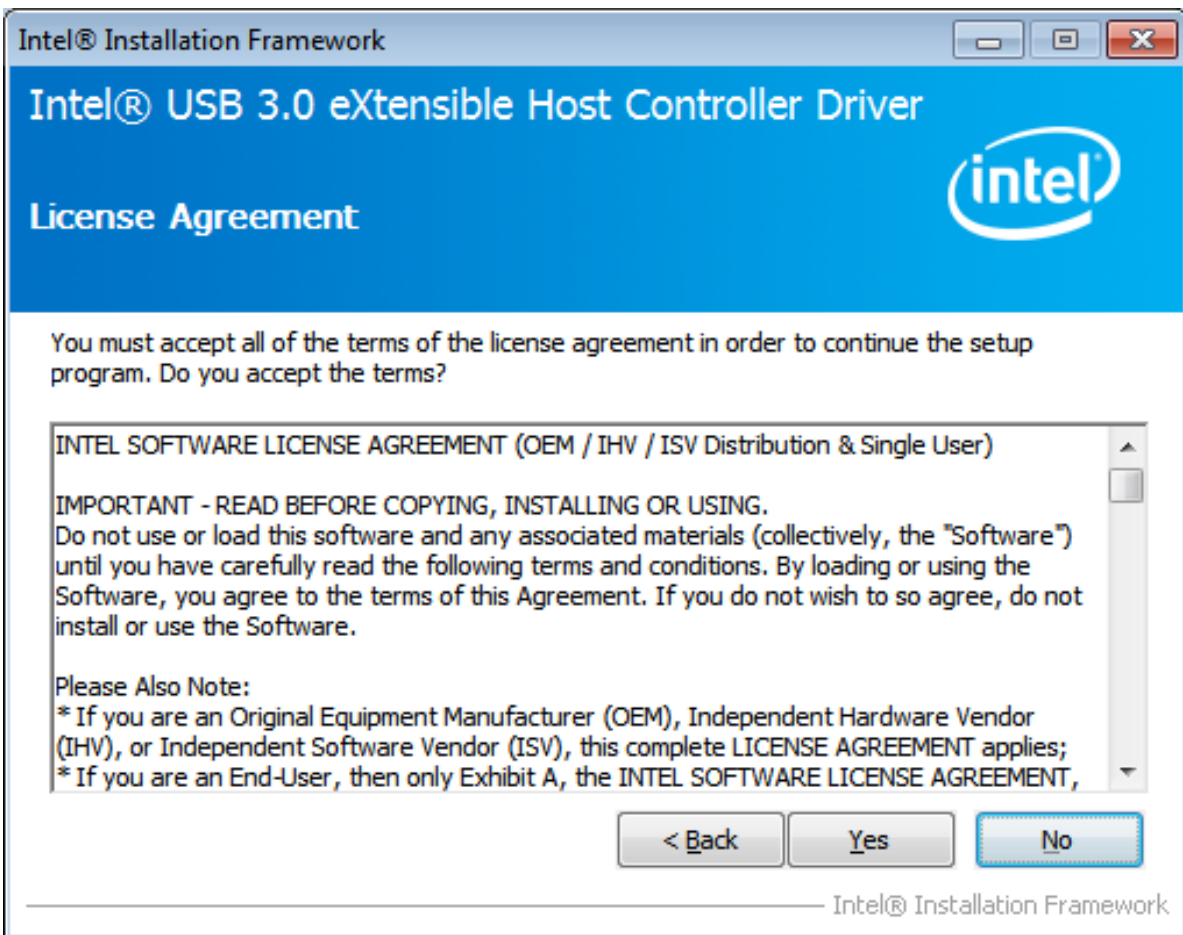

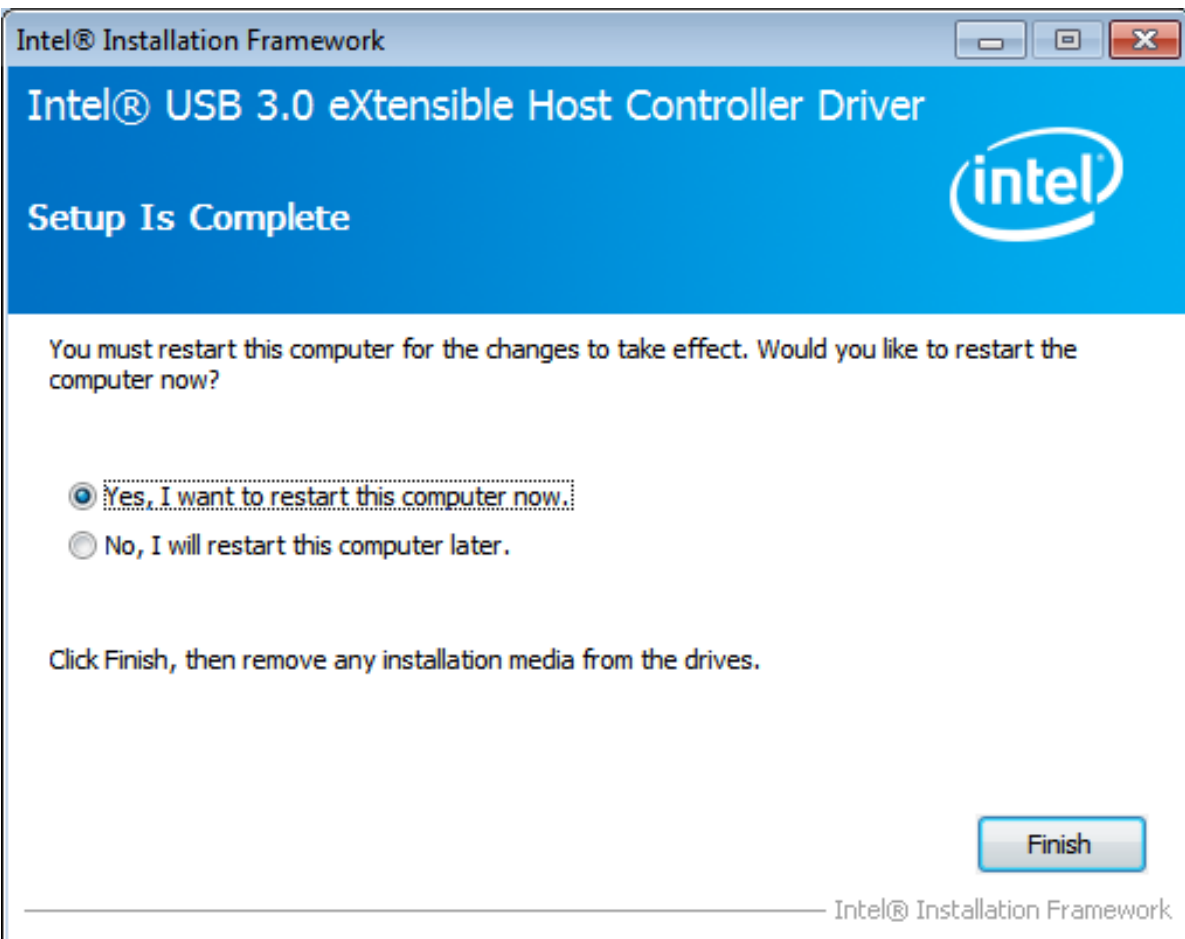
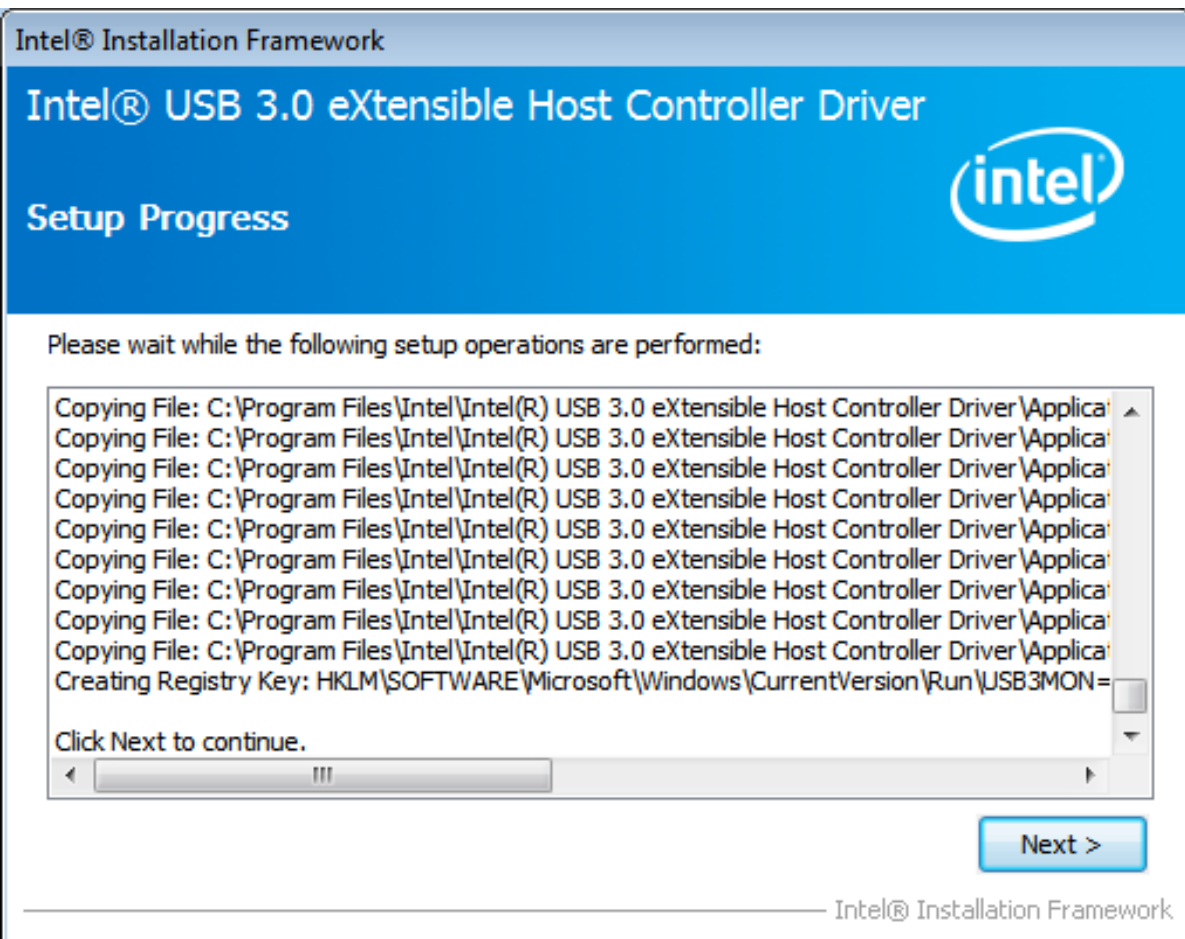

4.6 Intel(R) AMT Installation

To install the Intel(R) AMT Service, please follow the steps below.
Select AMT Service.

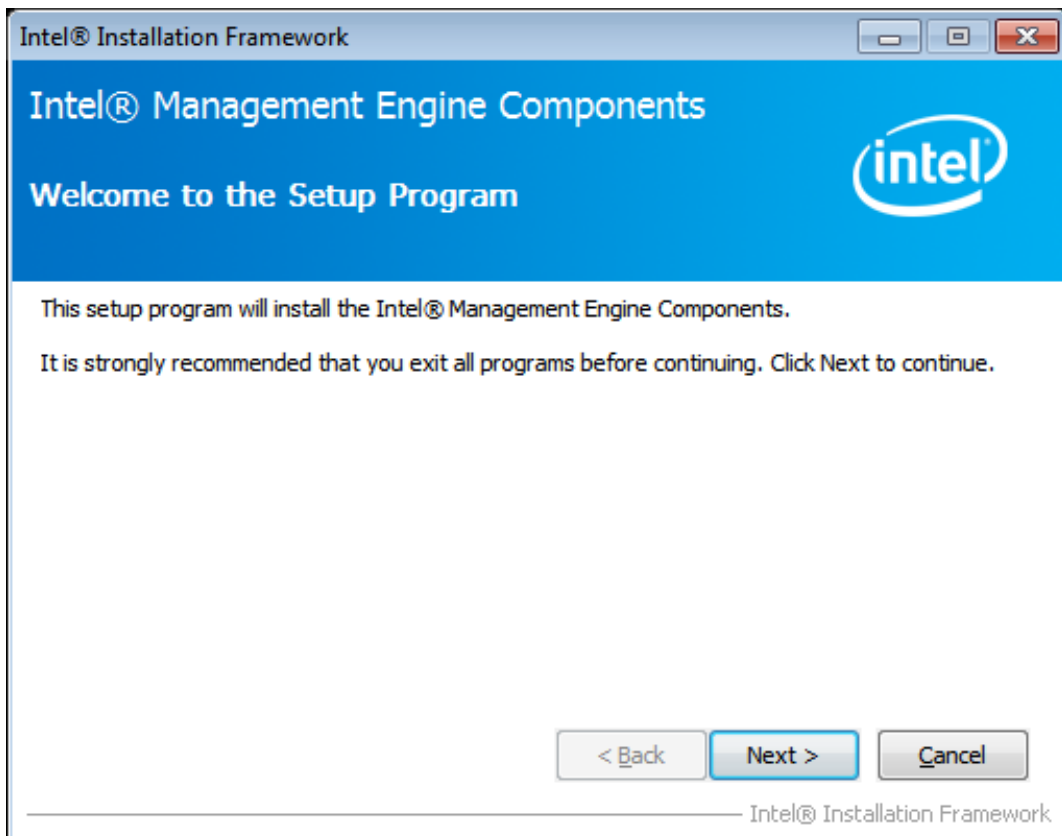

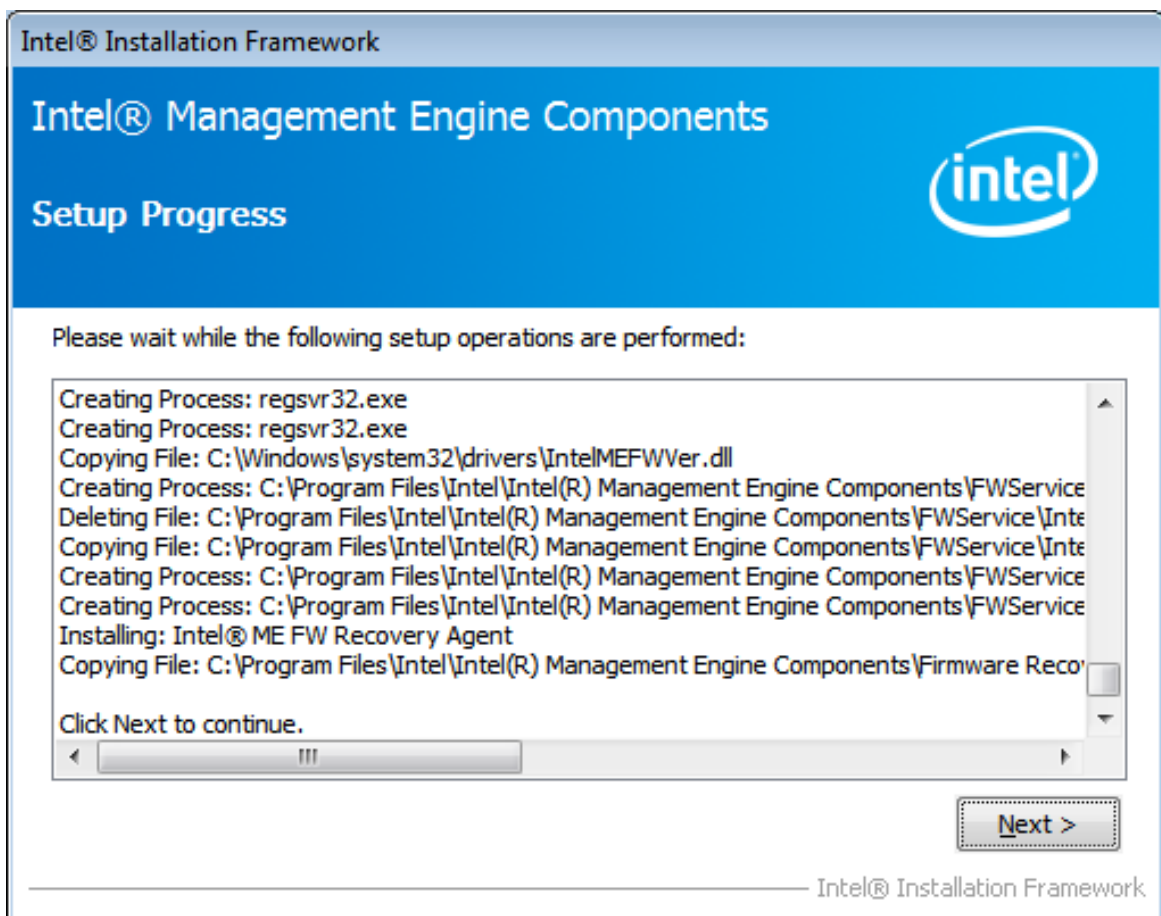
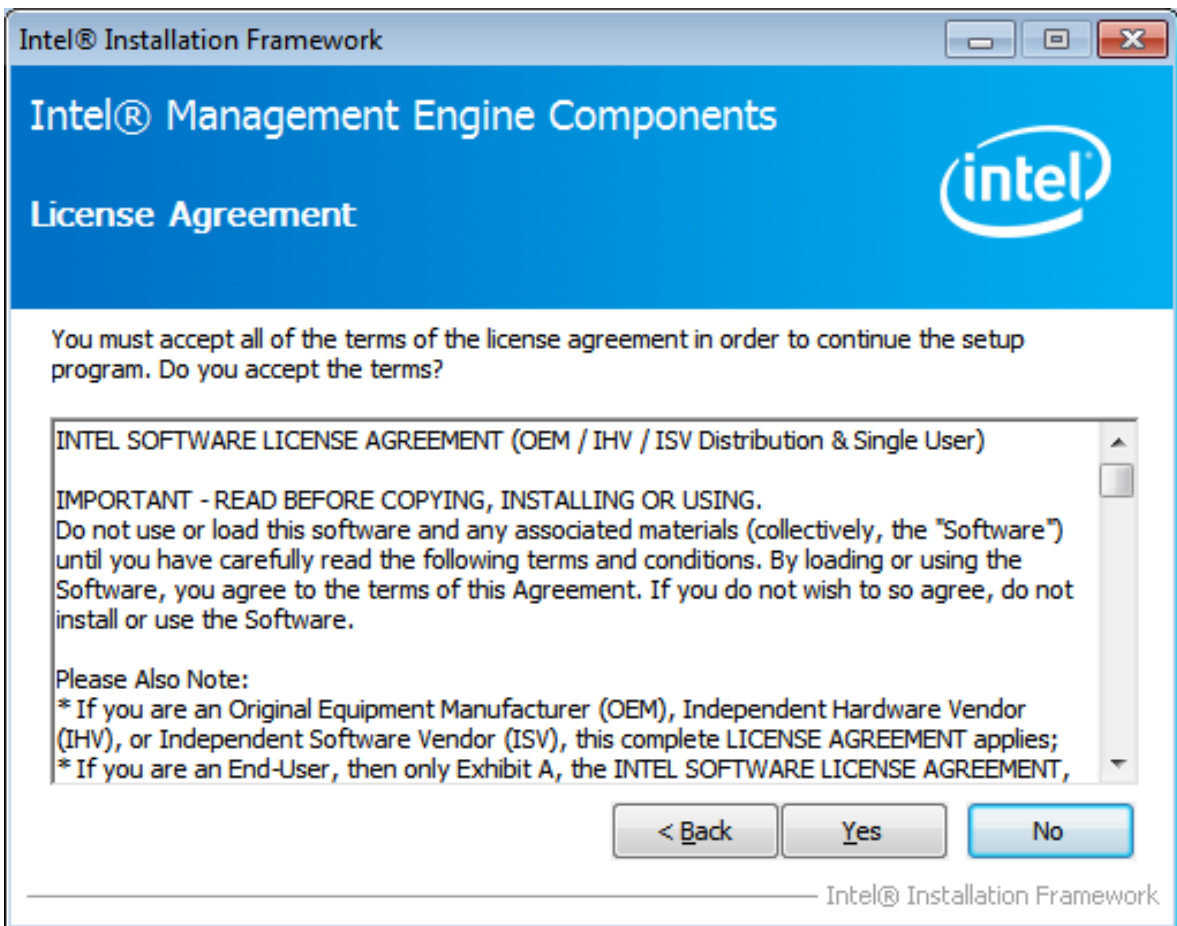

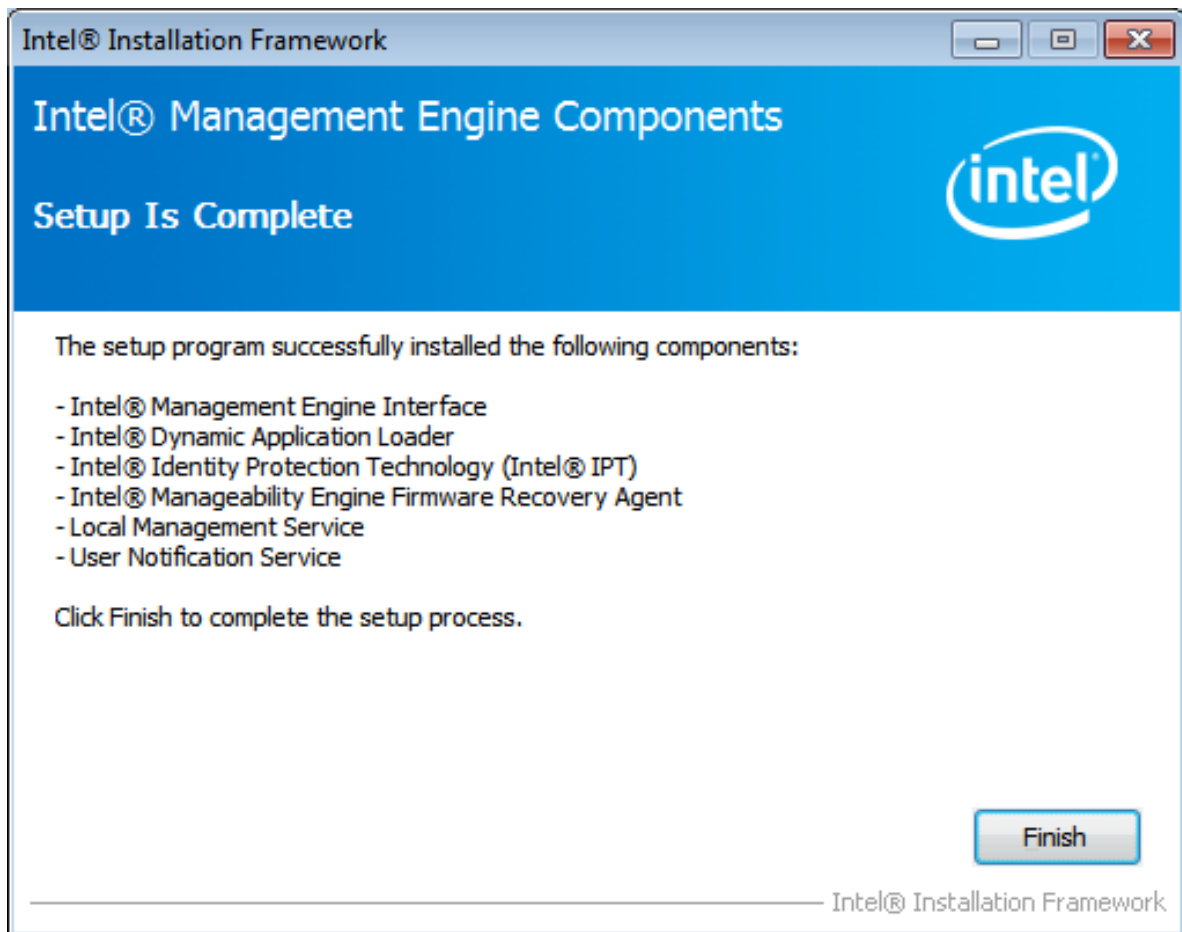

Click FINISH; A Driver Installation Complete.